

Overall length	Thread length	Position on basic dia.	Shank dia.	Size of square	Length of square
L	ℓ	ℓg	Ds	K	ℓk

- ① Spiral Fluted Taps (for blind hole)
- ② Spiral Fluted Taps (for through hole)
- ③ Spiral Pointed Taps (for through hole)
- ④ Hand Taps
- ⑤ Cemented Carbide Taps
- ⑥ Roll Taps
- ⑦ Special Thread Taps Simple inspection tools
- ⑧ Pipe Taps
- ⑨ Thread Mills Premium Thread Mills
- ⑩ Dies
- ⑪ Center Drills Centering Tools
- ⑫ Precision Machinery/ Medical Surgical Instruments



RLS-HT

Hand Taps for Camera Release Threads



Specification



■ Tap for the screws for installing camera release.

Tapping Speeds depending on Materials

Brass 黄銅	Brass castings 黄銅鑄物
~1 (m/min)	~1 (m/min)

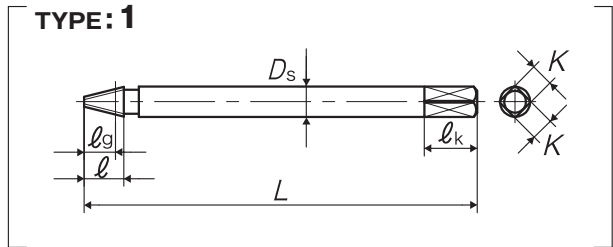

Segment : 1A

Size	Code	Chamfer	L (mm)	ℓ (mm)	ℓg (mm)	Ds (mm)	K (mm)	ℓk (mm)	No. of flutes	TYPE	MSRP
For Camera Release Threads											
3.4 × 0.5 × 28°	TY3.4G0LEB	-	52	5.25	4.15	4	3	7	3	1	¥ 10,300**

■ Bored hole size

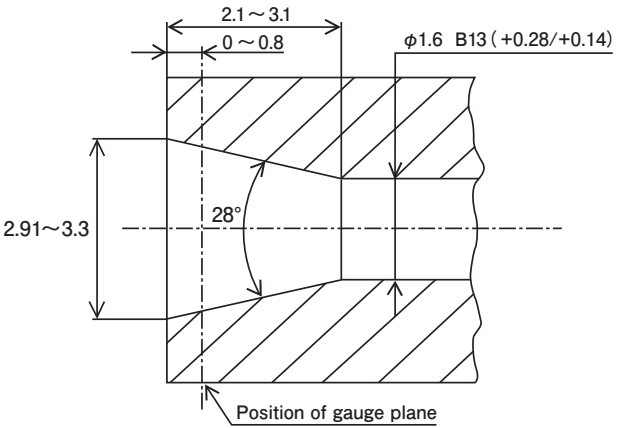

** = Specified Distribution Items. Made to order products.