

Overall length	Thread length	Thread + Neck length	Shank length	Shank dia.	Size of square	Length of square
L	ℓ	ℓn	ℓs	Ds	K	ℓk

- ① Spiral Fluted Taps (for blind hole)
- ② Spiral Fluted Taps (for through hole)
- ③ Spiral Pointed Taps (for through hole)
- ④ Hand Taps
- ⑤ Cemented Carbide Taps
- ⑥ Roll Taps
- ⑦ Special Thread Taps Simple Inspection Tools
- ⑧ Pipe Taps
- ⑨ Thread Mills
- ⑩ Dies
- ⑪ Center Drills Centering Tools



SIT

Simple Thread Inspection Tools

Specification

HSS

For icon explanation, refer to icon-1

For GO (GB)



For NOT GO (NB/WB)



■ Specification of SIT is available up to M48 (U1 3/4). For details, please contact us.

Product features

- Blue color for GO and red color for Not Go are used for easy identification and storage.
- Utilizing a high grade of HSS material, the gauge life has increased significantly.
- By using a stepped threads or tapered threads design at the front end of screw thread section, the problems in inspection were reduced while the work efficiency was improved. The tip of SIT gauge is easy to insert into an internal screw thread as the thread height gradually becomes larger. This is particularly effective when inspecting fine pitch threads.
- Note: Stepped threaded design is not used for Not Go.

Go and Not Go notations

These notations conform to the "gauge symbol" of JIS standards.

■ Metric thread

Type of Thread	Thread Element	Types of Screw Limit Gauges	Gauge Symbol
Internal Thread	Pitch Diameter	GO screw plug gauge	GP
		Not GO thread plug gauge	NP

The "SIT and SITD" have different dimensions like the length of the screw thread portion and the relief shape of the threads root with respect to plug gauge, GP / NP is not used for GO use and GB is for NOT GO NB.

■ Unified thread

Type of Thread	Thread Element	Types of Screw Limit Gauges	Gauge Symbol
Internal Thread	Pitch Diameter	GO screw plug gauge (common for both work and inspection)	GP
		Not GO thread plug gauge for work	WP
		Inspection type thread plug gauge	IP

For unified screw threads, for GO gauge use the GB and for a NOT GO gauge use the WB.

Both metric screw threads and unified screw threads are manufactured in accordance with JIS standards. For a reference point: the metric screw threads have been specified to be consistent with ISO while the unified screw threads have been specified as it was before the introduction of ANSI standard.

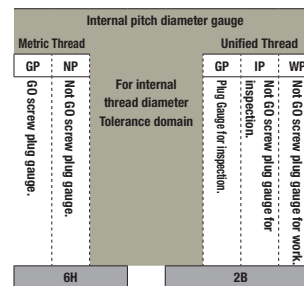

Accuracy of SIT

The single pitch diameter tolerance, the thread pitch tolerance and the threads half angle tolerance are important in the internal thread accuracy measurement and are manufactured using the same accuracy of thread plug gauges.

■ Comparison between the screw thread "GB-6H" and the screw thread plug gauge "GP-6H".

Unit : mm

Size	Major Diameter			Pitch Diameter			Pitch Tol. (±)	Thread Half Angle Tol. (± Min.)		
	Criteria Inch	Max	Min	Basic Dia.	Max	Min				
GB-6H M6 × 1	6.000	6.023	6.001	0.022	5.350	5.3675	5.3565	0.011	0.005	15
GP-6H M6 × 1	6.000	6.023	6.001	0.022	5.350	5.3675	5.3565	0.011	0.005	15

The pitch diameter is a single pitch diameter tolerance. The tolerance of the pitch also includes the deviation of the lead.

■ Comparison of Not GO thread portion "NB - 6H" and Not GO screw plug gauge "NP - 6H".

Unit : mm

Size	Major Diameter			Pitch Diameter			Pitch Tol. (±)	Thread Half Angle Tol. (± Min.)		
	Criteria Inch	Max	Min	Basic Dia.	Max	Min				
NB-6H M6 × 1	5.7055	5.7165	5.6945	0.022	5.500	5.511	5.500	0.011	0.005	16
NP-6H M6 × 1	5.7055	5.7165	5.6945	0.022	5.500	5.511	5.500	0.011	0.005	16

The pitch diameter is a single pitch diameter tolerance. The tolerance of the pitch also includes the deviation of the lead.

The screw thread precision is the same as a thread gauge, but some of the specifications like length of screw thread portion and the relief shape of the thread root are originated by YAMAWA. Therefore, these gauges are not to be called "thread gauge" and distinguished as "simple inspection tools for internal screw threads".



For improvement, spec may change without advance notice.

Overall length	Thread length	Thread + Neck length	Shank length	Shank dia.	Size of square	Length of square
L	ℓ	ℓ _n	ℓ _s	D _s	K	ℓ _k

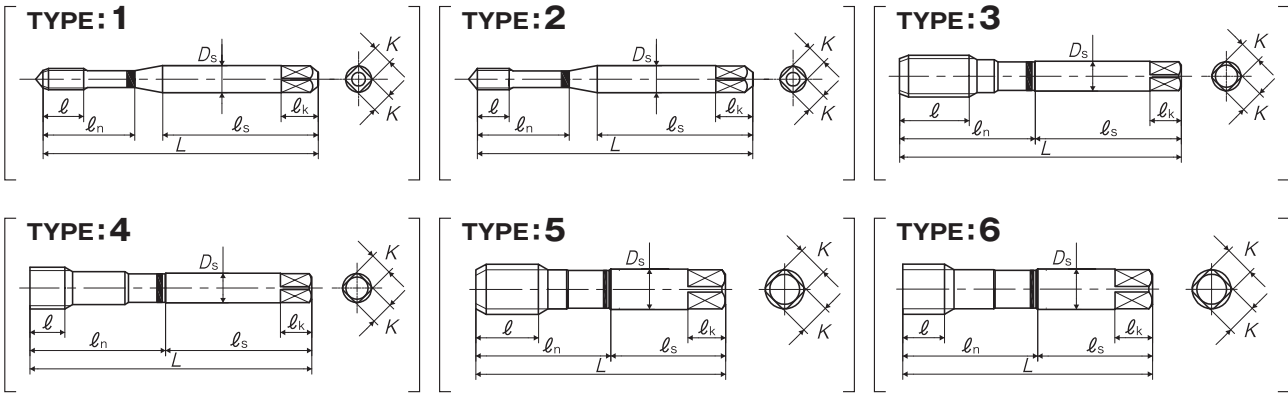

Segment : 7B

Size	Class	Code	L (mm)	ℓ (mm)	ℓ _n (mm)	ℓ _s (mm)	D _s (mm)	K (mm)	ℓ _k (mm)	TYPE	MSRP
For Metric Threads											
M2 × 0.4	GB	6H ITM62.0EG	42	5.5	12	27	3	2.5	5	1	¥ 6,300 □
M2 × 0.4	NB	6H ITM62.0EN	42	4.5	12	27	3	2.5	5	2	¥ 6,300 □
M2 × 0.25	GB	5H ITM52.0BG	42	4	12	27	3	2.5	5	1	¥ 10,000 □
M2 × 0.25	NB	5H ITM52.0BN	42	3.5	12	27	3	2.5	5	2	¥ 10,000 □
M2.2 × 0.45	GB	6H ITM62.2FG	42	5.5	12	27	3	2.5	5	1	¥ 6,300 □
M2.2 × 0.45	NB	6H ITM62.2FN	42	4.5	12	27	3	2.5	5	2	¥ 6,300 □
M2.2 × 0.25	GB	5H ITM52.2BG	42	4	12	27	3	2.5	5	1	¥ 10,000 □
M2.2 × 0.25	NB	5H ITM52.2BN	42	3.5	12	27	3	2.5	5	2	¥ 10,000 □
M2.3 × 0.4	GB	6H ITM62.3EG	42	5.5	12	27	3	2.5	5	1	¥ 6,300 □
M2.3 × 0.4	NB	6H ITM62.3EN	42	4.5	12	27	3	2.5	5	2	¥ 6,300 □
M2.3 × 0.25	GB	5H ITM52.3BG	42	4	12	27	3	2.5	5	1	¥ 10,000 □
M2.3 × 0.25	NB	5H ITM52.3BN	42	3.5	12	27	3	2.5	5	2	¥ 10,000 □
M2.5 × 0.45	GB	6H ITM62.5FG	46	5.5	14	29	3	2.5	5	1	¥ 5,990 □
M2.5 × 0.45	NB	6H ITM62.5FN	46	4.5	14	29	3	2.5	5	2	¥ 5,990 □
M2.5 × 0.35	GB	6H ITM62.5DG	46	4.5	14	29	3	2.5	5	1	¥ 9,420 □
M2.5 × 0.35	NB	6H ITM62.5DN	46	3.5	14	29	3	2.5	5	2	¥ 9,420 □
M2.6 × 0.45	GB	6H ITM62.6FG	46	5.5	14	29	3	2.5	5	1	¥ 5,990 □
M2.6 × 0.45	NB	6H ITM62.6FN	46	4.5	14	29	3	2.5	5	2	¥ 5,990 □
M2.6 × 0.35	GB	6H ITM62.6DG	46	4.5	14	29	3	2.5	5	1	¥ 9,420 □
M2.6 × 0.35	NB	6H ITM62.6DN	46	3.5	14	29	3	2.5	5	2	¥ 9,420 □
M3 × 0.5	GB	6H ITM63.0GG	46	5.5	14	26	4	3.2	6	1	¥ 5,560 □
M3 × 0.5	NB	6H ITM63.0GN	46	4.5	14	26	4	3.2	6	2	¥ 5,560 □
M3 × 0.35	GB	6H ITM63.0DG	46	4.5	14	26	4	3.2	6	1	¥ 8,550 □
M3 × 0.35	NB	6H ITM63.0DN	46	3.5	14	26	4	3.2	6	2	¥ 8,550 □
M3.5 × 0.6	GB	6H ITM63.5HG	52	7.5	16	29	5	4	7	1	¥ 5,560 □
M3.5 × 0.6	NB	6H ITM63.5HN	52	6	16	29	5	4	7	2	¥ 5,560 □
M3.5 × 0.35	GB	6H ITM63.5DG	52	4.5	16	29	5	4	7	1	¥ 7,930 □
M3.5 × 0.35	NB	6H ITM63.5DN	52	3.5	16	29	5	4	7	2	¥ 7,930 □
M4 × 0.7	GB	6H ITM64.0IG	52	7.5	17	29	5	4	7	1	¥ 5,100 □
M4 × 0.7	NB	6H ITM64.0IN	52	6	17	29	5	4	7	2	¥ 5,100 □
M4 × 0.5	GB	6H ITM64.0GG	52	7.5	17	29	5	4	7	1	¥ 6,680 □
M4 × 0.5	NB	6H ITM64.0GN	52	6	17	29	5	4	7	2	¥ 6,680 □
M4.5 × 0.75	GB	6H ITM64.5JG	60	7.5	21	33	5.5	4.5	7	1	¥ 6,740 □
M4.5 × 0.75	NB	6H ITM64.5JN	60	6	21	33	5.5	4.5	7	2	¥ 6,740 □
M4.5 × 0.5	GB	6H ITM64.5GG	60	7.5	21	33	5.5	4.5	7	1	¥ 7,650 □
M4.5 × 0.5	NB	6H ITM64.5GN	60	6	21	33	5.5	4.5	7	2	¥ 7,650 □
M5 × 0.8	GB	6H ITM65.0KG	60	10	22	33	5.5	4.5	7	1	¥ 5,100 □

※ = Specified Distribution Items. Made to order products. □=In stock at manufacturer.
For improvement, spec may change without advance notice.

Think threads with
YAMAWA

Spiral Fluted Taps
(for blind hole) ①

Spiral Fluted Taps
(for through hole) ②

Spiral Pointed Taps
(for through hole) ③

Hand Taps ④

Cemented
Carbide Taps ⑤

Roll Taps ⑥

Special Thread Taps
Simple inspection tools ⑦

Pipe Taps ⑧

Thread Mills ⑨

Dies ⑩

Center Drills
Centering Tools ⑪

Overall length	Thread length	Thread + Neck length	Shank length	Shank dia.	Size of square	Length of square
L	ℓ	ℓn	ℓs	Ds	K	ℓk

JIS

SIT Simple Thread Inspection Tools

① Spiral Fluted Taps (for blind hole)

② Spiral Fluted Taps (for through hole)

③ Spiral Pointed Taps (for through hole)

④ Hand Taps

⑤ Cemented Carbide Taps

⑥ Roll Taps

⑦ Special Thread Taps Simple Inspection Tools

⑧ Pipe Taps

⑨ Thread Mills

⑩ Dies

⑪ Center Drills Centering Tools

Size	Class	Code	L (mm)	ℓ (mm)	ℓn (mm)	ℓs (mm)	Ds (mm)	K (mm)	ℓk (mm)	TYPE	MSRP
M5 × 0.8	NB	6H ITM65.0KN	60	6	22	33	5.5	4.5	7	2	¥ 5,100 □
M5 × 0.5	GB	6H ITM65.0GG	60	7	22	33	5.5	4.5	7	1	¥ 7,650 □
M5 × 0.5	NB	6H ITM65.0GN	60	6	22	33	5.5	4.5	7	2	¥ 7,650 □
M5.5 × 0.5	GB	6H ITM65.5GG	62	7	26	33	6	4.5	7	1	¥ 7,950 □
M5.5 × 0.5	NB	6H ITM65.5GN	62	6	26	33	6	4.5	7	2	¥ 7,950 □
M6 × 1	GB	6H ITM66.0MG	62	10	26	33	6	4.5	7	1	¥ 5,300 □
M6 × 1	NB	6H ITM66.0MN	62	6	26	33	6	4.5	7	2	¥ 5,300 □
M6 × 0.75	GB	6H ITM66.0JG	62	7.5	26	33	6	4.5	7	1	¥ 6,360 □
M6 × 0.75	NB	6H ITM66.0JN	62	6	26	33	6	4.5	7	2	¥ 6,360 □
M7 × 1	GB	6H ITM67.0MG	70	12	34	36	6.2	5	8	3	¥ 5,790 □
M7 × 1	NB	6H ITM67.0MN	70	6	34	36	6.2	5	8	4	¥ 5,790 □
M7 × 0.75	GB	6H ITM67.0JG	70	9	34	36	6.2	5	8	3	¥ 6,950 □
M7 × 0.75	NB	6H ITM67.0JN	70	6	34	36	6.2	5	8	4	¥ 6,950 □
M8 × 1.25	GB	6H ITM68.0NG	70	15	34	36	6.2	5	8	3	¥ 5,790 □
M8 × 1.25	NB	6H ITM68.0NN	70	10	34	36	6.2	5	8	4	¥ 5,790 □
M8 × 1	GB	6H ITM68.0MG	70	12	34	36	6.2	5	8	3	¥ 5,790 □
M8 × 1	NB	6H ITM68.0MN	70	6	34	36	6.2	5	8	4	¥ 5,790 □
M8 × 0.75	GB	6H ITM68.0JG	70	9	34	36	6.2	5	8	3	¥ 6,950 □
M8 × 0.75	NB	6H ITM68.0JN	70	6	34	36	6.2	5	8	4	¥ 6,950 □
M9 × 1.25	GB	6H ITM69.0NG	75	15	37	38	7	5.5	8	3	¥ 6,750 □
M9 × 1.25	NB	6H ITM69.0NN	75	10	37	38	7	5.5	8	4	¥ 6,750 □
M9 × 1	GB	6H ITM69.0MG	75	12	37	38	7	5.5	8	3	¥ 6,750 □
M9 × 1	NB	6H ITM69.0MN	75	6	37	38	7	5.5	8	4	¥ 6,750 □
M9 × 0.75	GB	6H ITM69.0JG	75	9	37	38	7	5.5	8	3	¥ 6,750 □
M9 × 0.75	NB	6H ITM69.0JN	75	6	37	38	7	5.5	8	4	¥ 6,750 □
M10 × 1.5	GB	6H ITM60100G	75	15	37	38	7	5.5	8	3	¥ 5,790 □
M10 × 1.5	NB	6H ITM60100N	75	10	37	38	7	5.5	8	4	¥ 5,790 □
M10 × 1.25	GB	6H ITM6010NG	75	15	37	38	7	5.5	8	3	¥ 5,790 □
M10 × 1.25	NB	6H ITM6010NN	75	10	37	38	7	5.5	8	4	¥ 5,790 □
M10 × 1	GB	6H ITM6010MG	75	12	37	38	7	5.5	8	3	¥ 6,750 □
M10 × 1	NB	6H ITM6010MN	75	6	37	38	7	5.5	8	4	¥ 6,750 □
M10 × 0.75	GB	6H ITM6010JG	75	9	37	38	7	5.5	8	3	¥ 6,750 □
M10 × 0.75	NB	6H ITM6010JN	75	6	37	38	7	5.5	8	4	¥ 6,750 □
M11 × 1.5	GB	6H ITM60110G	82	19	40	42	8.5	6.5	9	3	¥ 7,140 □
M11 × 1.5	NB	6H ITM60110N	82	10	40	42	8.5	6.5	9	4	¥ 7,140 □
M11 × 1	GB	6H ITM6011MG	82	12	40	42	8.5	6.5	9	3	¥ 7,140 □
M11 × 1	NB	6H ITM6011MN	82	6	40	42	8.5	6.5	9	4	¥ 7,140 □
M11 × 0.75	GB	6H ITM6011JG	82	10	40	42	8.5	6.5	9	3	¥ 7,140 □
M11 × 0.75	NB	6H ITM6011JN	82	6	40	42	8.5	6.5	9	4	¥ 7,140 □
M12 × 1.75	GB	6H ITM6012PG	82	20	40	42	8.5	6.5	9	3	¥ 6,030 □
M12 × 1.75	NB	6H ITM6012PN	82	10	40	42	8.5	6.5	9	4	¥ 6,030 □
M12 × 1.5	GB	6H ITM60120G	82	20	40	42	8.5	6.5	9	3	¥ 6,030 □
M12 × 1.5	NB	6H ITM60120N	82	10	40	42	8.5	6.5	9	4	¥ 6,030 □
M12 × 1.25	GB	6H ITM6012NG	82	15	40	42	8.5	6.5	9	3	¥ 6,030 □
M12 × 1.25	NB	6H ITM6012NN	82	10	40	42	8.5	6.5	9	4	¥ 6,030 □
M12 × 1	GB	6H ITM6012MG	82	12	40	42	8.5	6.5	9	3	¥ 7,140 □
M12 × 1	NB	6H ITM6012MN	82	6	40	42	8.5	6.5	9	4	¥ 7,140 □
M14 × 2	GB	6H ITM6014QG	88	20	43	45	10.5	8	11	3	¥ 6,320 □
M14 × 2	NB	6H ITM6014QN	88	12	43	45	10.5	8	11	4	¥ 6,320 □
M14 × 1.5	GB	6H ITM60140G	88	20	43	45	10.5	8	11	3	¥ 6,320 □



※ = Specified Distribution Items. Made to order products. □=In stock at manufacturer.
For improvement, spec may change without advance notice.

Overall length	Thread length	Thread + Neck length	Shank length	Shank dia.	Size of square	Length of square
L	ℓ	ℓn	ℓs	Ds	K	ℓk

SIT Simple Thread Inspection Tools

Size	Class	Code	L (mm)	ℓ (mm)	ℓn (mm)	ℓs (mm)	Ds (mm)	K (mm)	ℓk (mm)	TYPE	MSRP
M14 × 1.5	NB	6H ITM60140N	88	12	43	45	10.5	8	11	4	¥ 6,320 □
M14 × 1.25	GB	6H ITM6014NG	88	15	43	45	10.5	8	11	3	¥ 7,260 □
M14 × 1.25	NB	6H ITM6014NN	88	12	43	45	10.5	8	11	4	¥ 7,260 □
M14 × 1	GB	6H ITM6014MG	88	12	43	45	10.5	8	11	3	¥ 7,260 □
M14 × 1	NB	6H ITM6014MN	88	6	43	45	10.5	8	11	4	¥ 7,260 □
M15 × 1.5	GB	6H ITM60150G	95	19	47	48	12.5	10	13	3	¥ 7,340 □
M15 × 1.5	NB	6H ITM60150N	95	10	47	48	12.5	10	13	4	¥ 7,340 □
M15 × 1	GB	6H ITM6015MG	95	12	47	48	12.5	10	13	3	¥ 7,340 □
M15 × 1	NB	6H ITM6015MN	95	10	47	48	12.5	10	13	4	¥ 7,340 □
M16 × 2	GB	6H ITM60160G	95	20	47	48	12.5	10	13	3	¥ 6,860 □
M16 × 2	NB	6H ITM60160N	95	12	47	48	12.5	10	13	4	¥ 6,860 □
M16 × 1.5	GB	6H ITM60160G	95	20	47	48	12.5	10	13	3	¥ 6,860 □
M16 × 1.5	NB	6H ITM60160N	95	12	47	48	12.5	10	13	4	¥ 6,860 □
M16 × 1	GB	6H ITM6016MG	95	12	47	48	12.5	10	13	3	¥ 7,340 □
M16 × 1	NB	6H ITM6016MN	95	8	47	48	12.5	10	13	4	¥ 7,340 □
M17 × 1.5	GB	6H ITM60170G	100	19	49	51	14	11	14	3	¥ 9,420 □
M17 × 1.5	NB	6H ITM60170N	100	10	49	51	14	11	14	4	¥ 9,420 □
M17 × 1	GB	6H ITM6017MG	100	12	49	51	14	11	14	3	¥ 9,420 □
M17 × 1	NB	6H ITM6017MN	100	10	49	51	14	11	14	4	¥ 9,420 □
M18 × 2.5	GB	6H ITM6018RG	100	25	49	51	14	11	14	3	¥ 8,530 □
M18 × 2.5	NB	6H ITM6018RN	100	16	49	51	14	11	14	4	¥ 8,530 □
M18 × 2	GB	6H ITM6018QG	100	20	49	51	14	11	14	3	¥ 8,530 □
M18 × 2	NB	6H ITM6018QN	100	12	49	51	14	11	14	4	¥ 8,530 □
M18 × 1.5	GB	6H ITM60180G	100	20	49	51	14	11	14	3	¥ 8,530 □
M18 × 1.5	NB	6H ITM60180N	100	12	49	51	14	11	14	4	¥ 8,530 □
M18 × 1	GB	6H ITM6018MG	100	12	49	51	14	11	14	3	¥ 9,420 □
M18 × 1	NB	6H ITM6018MN	100	8	49	51	14	11	14	4	¥ 9,420 □
M20 × 2.5	GB	6H ITM6020RG	105	25	55	50	15	12	15	5	¥ 10,400 □
M20 × 2.5	NB	6H ITM6020RN	105	16	55	50	15	12	15	6	¥ 10,400 □
M20 × 2	GB	6H ITM6020QG	105	20	55	50	15	12	15	5	¥ 10,400 □
M20 × 2	NB	6H ITM6020QN	105	12	55	50	15	12	15	6	¥ 10,400 □
M20 × 1.5	GB	6H ITM60200G	105	20	55	50	15	12	15	5	¥ 10,400 □
M20 × 1.5	NB	6H ITM60200N	105	12	55	50	15	12	15	6	¥ 10,400 □
M20 × 1	GB	6H ITM6020MG	105	14	55	50	15	12	15	5	¥ 13,300 □
M20 × 1	NB	6H ITM6020MN	105	8	55	50	15	12	15	6	¥ 13,300 □
M22 × 2.5	GB	6H ITM6022RG	115	33	60	55	17	13	16	5	¥ 14,800 □
M22 × 2.5	NB	6H ITM6022RN	115	16	60	55	17	13	16	6	¥ 14,800 □
M22 × 2	GB	6H ITM6022QG	115	20	60	55	17	13	16	5	¥ 14,800 □
M22 × 2	NB	6H ITM6022QN	115	14	60	55	17	13	16	6	¥ 14,800 □
M22 × 1.5	GB	6H ITM60220G	115	20	60	55	17	13	16	5	¥ 14,800 □
M22 × 1.5	NB	6H ITM60220N	115	14	60	55	17	13	16	6	¥ 14,800 □
M22 × 1	GB	6H ITM6022MG	115	14	60	55	17	13	16	5	¥ 17,600 □
M22 × 1	NB	6H ITM6022MN	115	8	60	55	17	13	16	6	¥ 17,600 □
M24 × 3	GB	6H ITM6024SG	120	30	65	55	19	15	18	5	¥ 18,300 □
M24 × 3	NB	6H ITM6024SN	120	20	65	55	19	15	18	6	¥ 18,300 □
M24 × 2	GB	6H ITM6024QG	120	20	65	55	19	15	18	5	¥ 18,300 □
M24 × 2	NB	6H ITM6024QN	120	14	65	55	19	15	18	6	¥ 18,300 □
M24 × 1.5	GB	6H ITM60240G	120	20	65	55	19	15	18	5	¥ 18,300 □
M24 × 1.5	NB	6H ITM60240N	120	14	65	55	19	15	18	6	¥ 18,300 □
M24 × 1	GB	6H ITM6024MG	120	14	65	55	19	15	18	5	¥ 23,500 □

Spiral Fluted Taps
(for blind hole) ①Spiral Fluted Taps
(for through hole) ②Spiral Pointed Taps
(for through hole) ③

Hand Taps ④

Cemented Carbide Taps ⑤

Roll Taps ⑥

Special Thread Taps
Simple inspection tools ⑦

Pipe Taps ⑧

Thread Mills ⑨

Dies ⑩

Center Drills
Centering Tools ⑪

Overall length	Thread length	Thread + Neck length	Shank length	Shank dia.	Size of square	Length of square
L	ℓ	ℓn	ℓs	Ds	K	ℓk

JIS

SIT Simple Thread Inspection Tools

① Spiral Fluted Taps (for blind hole)

② Spiral Fluted Taps (for through hole)

③ Spiral Pointed Taps (for through hole)

④ Hand Taps

⑤ Cemented Carbide Taps

⑥ Roll Taps

⑦ Special Thread Taps Simple Inspection Tools

⑧ Pipe Taps

⑨ Thread Mills

⑩ Dies

⑪ Center Drills Centering Tools

Size	Class	Code	L (mm)	ℓ (mm)	ℓn (mm)	ℓs (mm)	Ds (mm)	K (mm)	ℓk (mm)	TYPE	MSRP
M24 × 1	NB	6H ITM6024MN	120	8	65	55	19	15	18	6	¥ 23,500 □
For Unified Threads											
No. 2-56UNC	GB	2B ITM2UN2EG	42	4.5	12	26	3	2.5	5	1	¥ 7,100 □
No. 2-56UNC	WB	2B ITM2UN2EN	42	3.5	12	26	3	2.5	5	2	¥ 7,100 □
No. 2-64UNF	GB	2B ITM2UN2DG	42	4.5	12	26	3	2.5	5	1	¥ 7,100 □
No. 2-64UNF	WB	2B ITM2UN2DN	42	3.5	12	26	3	2.5	5	2	¥ 7,100 □
No. 3-48UNC	GB	2B ITM2UN3FG	46	6.5	14	28	3	2.5	5	1	¥ 6,860 □
No. 3-48UNC	WB	2B ITM2UN3FN	46	3.5	14	28	3	2.5	5	2	¥ 6,860 □
No. 3-56UNF	GB	2B ITM2UN3EG	46	6.5	14	28	3	2.5	5	1	¥ 6,860 □
No. 3-56UNF	WB	2B ITM2UN3EN	46	3.5	14	28	3	2.5	5	2	¥ 6,860 □
No. 4-40UNC	GB	2B ITM2UN4HG	46	6.5	14	25	4	3.2	6	1	¥ 6,500 □
No. 4-40UNC	WB	2B ITM2UN4HN	46	3.5	14	25	4	3.2	6	2	¥ 6,500 □
No. 4-48UNF	GB	2B ITM2UN4FG	46	6.5	14	25	4	3.2	6	1	¥ 6,500 □
No. 4-48UNF	WB	2B ITM2UN4FN	46	3.5	14	25	4	3.2	6	2	¥ 6,500 □
No. 5-40UNC	GB	2B ITM2UN5HG	52	6.5	16	28	5	4	7	1	¥ 6,200 □
No. 5-40UNC	WB	2B ITM2UN5HN	52	3.5	16	28	5	4	7	2	¥ 6,200 □
No. 5-44UNF	GB	2B ITM2UN5GG	52	6.5	16	28	5	4	7	1	¥ 6,200 □
No. 5-44UNF	WB	2B ITM2UN5GN	52	3.5	16	28	5	4	7	2	¥ 6,200 □
No. 6-32UNC	GB	2B ITM2UN6JG	52	7	17	27	5	4	7	1	¥ 6,200 □
No. 6-32UNC	WB	2B ITM2UN6JN	52	3.5	17	27	5	4	7	2	¥ 6,200 □
No. 6-40UNF	GB	2B ITM2UN6HG	52	7	17	27	5	4	7	1	¥ 6,200 □
No. 6-40UNF	WB	2B ITM2UN6HN	52	3.5	17	27	5	4	7	2	¥ 6,200 □
No. 8-32UNC	GB	2B ITM2UN8JG	60	9	22	31	5.5	4.5	7	1	¥ 6,140 □
No. 8-32UNC	WB	2B ITM2UN8JN	60	5	22	31	5.5	4.5	7	2	¥ 6,140 □
No. 8-36UNF	GB	2B ITM2UN8IG	60	9	22	31	5.5	4.5	7	1	¥ 6,140 □
No. 8-36UNF	WB	2B ITM2UN8IN	60	5	22	31	5.5	4.5	7	2	¥ 6,140 □
No. 10-24UNC	GB	2B ITM2UNAMG	60	9.5	22	32	5.5	4.5	7	1	¥ 6,140 □
No. 10-24UNC	WB	2B ITM2UNAMN	60	5	22	32	5.5	4.5	7	2	¥ 6,140 □
No. 10-32UNF	GB	2B ITM2UNAJG	60	9.5	22	32	5.5	4.5	7	1	¥ 6,140 □
No. 10-32UNF	WB	2B ITM2UNAJN	60	5	22	32	5.5	4.5	7	2	¥ 6,140 □
No. 12-24UNC	GB	2B ITM2UNCMG	62	9.5	26	32	6	4.5	7	1	¥ 6,100 □
No. 12-24UNC	WB	2B ITM2UNCMN	62	5	26	32	6	4.5	7	2	¥ 6,100 □
No. 12-28UNF	GB	2B ITM2UNCKG	62	9.5	26	32	6	4.5	7	1	¥ 6,100 □
No. 12-28UNF	WB	2B ITM2UNCKN	62	5	26	32	6	4.5	7	2	¥ 6,100 □
1/4-20UNC	GB	2B ITM2U04NG	62	15	26	32	6	4.5	7	1	¥ 6,100 □
1/4-20UNC	WB	2B ITM2U04NN	62	10	26	32	6	4.5	7	2	¥ 6,100 □
1/4-28UNF	GB	2B ITM2U04KG	62	12	26	32	6	4.5	7	1	¥ 6,100 □
1/4-28UNF	WB	2B ITM2U04KN	62	7	26	32	6	4.5	7	2	¥ 6,100 □
5/16-18UNC	GB	2B ITM2U05OG	70	15	34	36	6.2	5	8	3	¥ 6,250 □
5/16-18UNC	WB	2B ITM2U05ON	70	10	34	36	6.2	5	8	4	¥ 6,250 □
5/16-24UNF	GB	2B ITM2U05MG	70	15	34	36	6.2	5	8	3	¥ 6,250 □
5/16-24UNF	WB	2B ITM2U05MN	70	7	34	36	6.2	5	8	4	¥ 6,250 □
3/8-16UNC	GB	2B ITM2U06PG	75	17	37	38	7	5.5	8	3	¥ 6,340 □
3/8-16UNC	WB	2B ITM2U06PN	75	10	37	38	7	5.5	8	4	¥ 6,340 □
3/8-24UNF	GB	2B ITM2U06MG	75	17	37	38	7	5.5	8	3	¥ 6,340 □
3/8-24UNF	WB	2B ITM2U06MN	75	10	37	38	7	5.5	8	4	¥ 6,340 □
7/16-14UNC	GB	2B ITM2U07QG	82	17	40	42	8.5	6.5	9	3	¥ 6,560 □
7/16-14UNC	WB	2B ITM2U07QN	82	10	40	42	8.5	6.5	9	4	¥ 6,560 □
7/16-20UNF	GB	2B ITM2U07NG	82	17	40	42	8.5	6.5	9	3	¥ 6,560 □
7/16-20UNF	WB	2B ITM2U07NN	82	10	40	42	8.5	6.5	9	4	¥ 6,560 □



※ = Specified Distribution Items. Made to order products. □=In stock at manufacturer.
For improvement, spec may change without advance notice.

Overall length	Thread length	Thread + Neck length	Shank length	Shank dia.	Size of square	Length of square
L	ℓ	ℓn	ℓs	Ds	K	ℓk

SIT Simple Thread Inspection Tools

Size	Class	Code	L (mm)	ℓ (mm)	ℓn (mm)	ℓs (mm)	Ds (mm)	K (mm)	ℓk (mm)	TYPE	MSRP
1/2-13UNC	GB	2B ITM2U08RG	88	17	43	45	10.5	8	11	3	¥ 6,890 □
1/2-13UNC	WB	2B ITM2U08RN	88	13	43	45	10.5	8	11	4	¥ 6,890 □
1/2-20UNF	GB	2B ITM2U08NG	88	17	43	45	10.5	8	11	3	¥ 6,890 □
1/2-20UNF	WB	2B ITM2U08NN	88	10	43	45	10.5	8	11	4	¥ 6,890 □
9/16-12UNC	GB	2B ITM2U09SG	95	26	47	48	12.5	10	13	3	¥ 7,030 □
9/16-12UNC	WB	2B ITM2U09SN	95	17	47	48	12.5	10	13	4	¥ 7,030 □
9/16-18UNF	GB	2B ITM2U090G	95	20	47	48	12.5	10	13	3	¥ 7,030 □
9/16-18UNF	WB	2B ITM2U090N	95	13	47	48	12.5	10	13	4	¥ 7,030 □
5/8-11UNC	GB	2B ITM2U10UG	95	26	47	48	12.5	10	13	3	¥ 7,030 □
5/8-11UNC	WB	2B ITM2U10UN	95	17	47	48	12.5	10	13	4	¥ 7,030 □
5/8-18UNF	GB	2B ITM2U100G	95	20	47	48	12.5	10	13	3	¥ 7,030 □
5/8-18UNF	WB	2B ITM2U100N	95	13	47	48	12.5	10	13	4	¥ 7,030 □

Spiral Fluted Taps
(for blind hole) ①Spiral Fluted Taps
(for through hole) ②Spiral Pointed Taps
(for through hole) ③

Hand Taps ④

Cemented
Carbide Taps ⑤

Roll Taps ⑥

Special Thread Taps
Simple Inspection Tools ⑦

Pipe Taps ⑧

Thread Mills ⑨

Dies ⑩

Center Drills
Centering Tools ⑪