

Outside diameter	Thickness	Position of basic dia.
D	T	lg

## JIS

① Spiral Fluted Taps  
(for blind hole)

② Spiral Fluted Taps  
(for through hole)

③ Spiral Pointed Taps  
(for through hole)

④ Hand Taps

⑤ Cemented Carbide Taps

⑥ Roll Taps

⑦ Special Thread Taps  
Simple inspection tools

⑧ Pipe Taps

⑨ Thread Mills  
Premium Thread Mills

⑩ Dies

⑪ Center Drills  
Centering Tools

⑫ Precision Machinery/  
Medical Surgical Instruments

## JIS

# JIS

## D PT

### Solid Round Dies for Taper Pipe Threads



#### Specification



■ The D PT is a solid round dies for PT external tapered pipe thread processing with improved runout accuracy.

#### Tapping Speeds depending on Materials

Low carbon steels 低碳素鋼	Medium carbon steels 中炭素鋼	Cast irons 鑄鐵	Brass 黃銅	Brass castings 黃銅鑄物	Wrought aluminum アルミ圧延材	Aluminum alloy castings アルミ合金鑄物
2.5~5 (m/min)	2.5~5 (m/min)	2.5~5 (m/min)	2.5~5 (m/min)	2.5~5 (m/min)	2.5~5 (m/min)	2.5~5 (m/min)

TYPE: 2

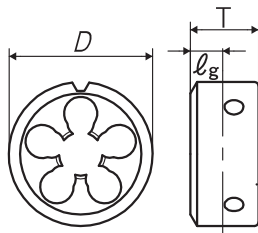

TYPE: 1

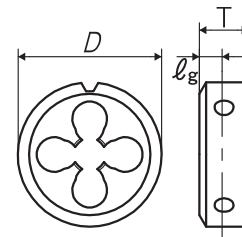

TYPE: 3

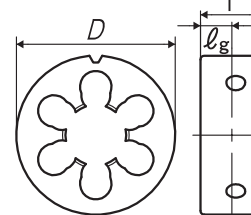

Segment : 3G

Size	Code	D (mm)	T (mm)	lg (mm)	Clearance holes	TYPE	MSRP
For PT Threads							
PT 1/16-28	TYJPT010NEBC	38	13	6	4	1	¥ 14,900 <sup>**</sup>
PT 1/8-28	TYJPT020NEBC	38	13	6	4	1	¥ 14,900
PT 1/4-19	TYJPT040NEBC	38	18	8.5	5	2	¥ 14,900
PT 3/8-19	TYMPT060NEBC	50	22	10	5	2	¥ 23,800
PT 1/2-14	TYMPT080NEBC	50	22	12	6	2	¥ 23,800
PT 5/8-14	TYRPT100NEBC	63	24	12	6	3	¥ 70,300 <sup>**</sup>
PT 3/4-14	TYRPT120NEBC	63	24	12.5	6	3	¥ 62,300
PT 7/8-14	TYUPT140NEBC	75	30	12.5	6	3	¥ 126,000 <sup>**</sup>
PT 1 -11	TYUPT160NEBC	75	30	15	6	3	¥ 111,000
PT 1 1/4-11	TYUPT200NEBC	75	30	15	6	3	¥ 111,000 <sup>**</sup>
PT 1 1/2-11	TYUPT240NEBC	75	30	15	6	3	¥ 111,000 <sup>**</sup>
PT 2 -11	TYIPT320NEBC	105	36	17.5	8	3	¥ 268,000 <sup>**</sup>