

Outside diameter	Thickness	Position of basic dia.
D	T	lg

S
JIS

D PT LH

Solid Round Dies for Taper Pipe Threads, for Left Hand Threads



Specification



■ The D PT LH are solid round dies for left hand external PT tapered pipe threads that have improved die runout accuracy.

Tapping Speeds depending on Materials

Low carbon steels 低碳素鋼 2.5~5 (m/min)	Medium carbon steels 中炭素鋼 2.5~5 (m/min)	Cast irons 鑄鉄 2.5~5 (m/min)	Brass 黄銅 2.5~5 (m/min)	Brass castings 黄銅鑄物 2.5~5 (m/min)	Wrought aluminum アルミ圧延材 2.5~5 (m/min)	Aluminum alloy castings アルミ合金鑄物 2.5~5 (m/min)
---	--	--------------------------------------	---------------------------------	--	--	--

- ① Spiral Fluted Taps (for blind hole)
- ② Spiral Fluted Taps (for through hole)
- ③ Spiral Pointed Taps (for through hole)
- ④ Hand Taps
- ⑤ Cemented Carbide Taps
- ⑥ Roll Taps
- ⑦ Special Thread Taps Simple inspection tools
- ⑧ Pipe Taps
- ⑨ Thread Mills Premium Thread Mills
- ⑩ Dies
- ⑪ Center Drills Centering Tools
- ⑫ Precision Machinery/Metal Surgical Instruments

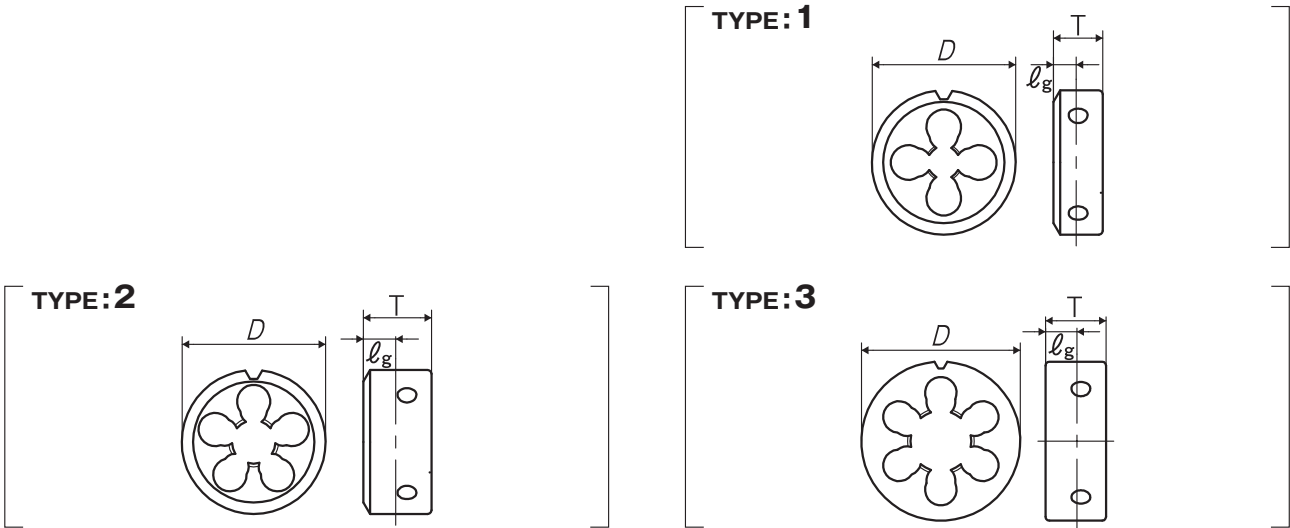

Segment : 3G

Size	Code	D (mm)	T (mm)	lg (mm)	Clearance holes	TYPE	MSRP
For PT Threads							
PT 1/8-28	GYJPT020NEBC	38	13	6	4	1	¥ 22,300*
PT 1/4-19	GYJPT040NEBC	38	18	8.5	5	2	¥ 22,300*
PT 3/8-19	GYMPT060NEBC	50	22	10	5	2	¥ 35,600*
PT 1/2-14	GYMPT080NEBC	50	22	12	6	2	¥ 35,600*
PT 3/4-14	GYRPT120NEBC	63	24	12.5	6	3	¥ 93,500*
PT 1 -11	GYUPT160NEBC	75	30	15	6	3	¥ 166,000*

* = Specified Distribution Items. Made to order products.