

| Outside diameter | Thickness | Position of basic dia. |
|------------------|-----------|------------------------|
| D | T | lg |

JIS

- ① Spiral Fluted Taps (for blind hole)
- ② Spiral Fluted Taps (for through hole)
- ③ Spiral Pointed Taps (for through hole)
- ④ Hand Taps
- ⑤ Cemented Carbide Taps
- ⑥ Roll Taps
- ⑦ Special Thread Taps (Simple inspection tools)
- ⑧ Pipe Taps
- ⑨ Thread Mills (Premium Thread Mills)
- ⑩ Dies
- ⑪ Center Drills (Centering Tools)
- ⑫ Precision Machinery/ Medical Surgical Instruments



D NPT

Solid Round Dies for American Taper Pipe Threads



Specification



■ The D NPT are solid round dies for American external tapered pipe threads with improved runout accuracy.

Tapping Speeds depending on Materials

| | | | | | | |
|---|--|--------------------------------------|---------------------------------|--|--|--|
| Low carbon steels 低碳素鋼 2.5~5 (m/min) | Medium carbon steels 中炭素鋼 2.5~5 (m/min) | Cast irons 鑄鐵 2.5~5 (m/min) | Brass 黃銅 2.5~5 (m/min) | Brass castings 黃銅鑄物 2.5~5 (m/min) | Wrought aluminum アルミ圧延材 2.5~5 (m/min) | Aluminum alloy castings アルミ合金鑄物 2.5~5 (m/min) |
|---|--|--------------------------------------|---------------------------------|--|--|--|

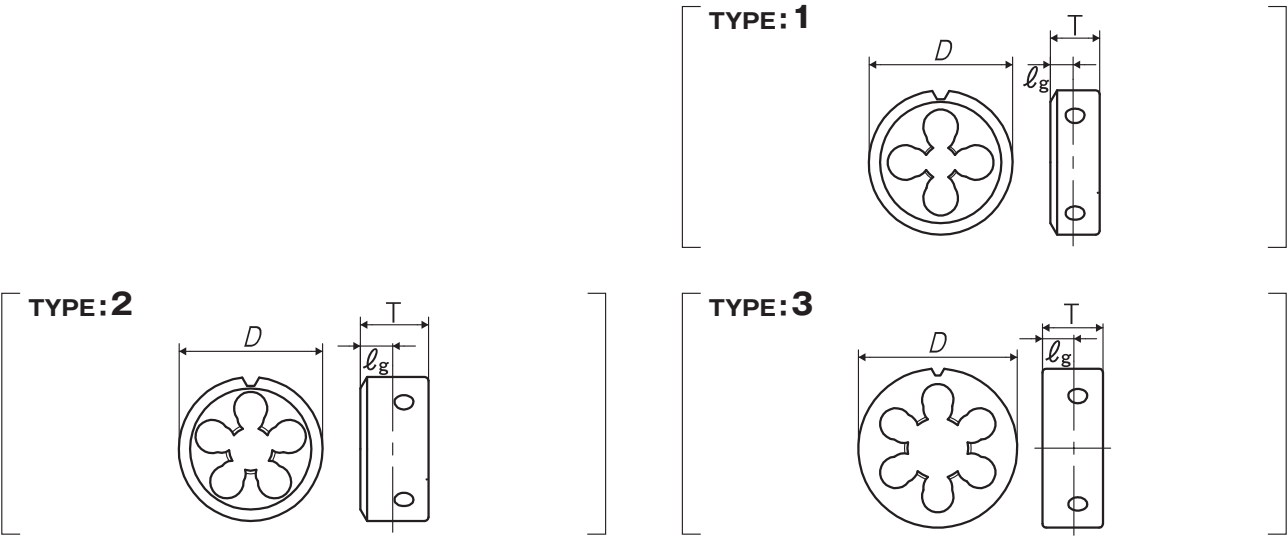

Segment : 3G

| Size | Code | D (mm) | T (mm) | lg (mm) | Clearance holes | TYPE | MSRP |
|------------------|--------------|--------|--------|---------|-----------------|------|------------------------|
| For NPT Threads | | | | | | | |
| 1/16-27 NPT | TYJNT010NEBC | 38 | 13 | 5 | 4 | 1 | ¥ 17,700 [*] |
| 1/8-27 NPT | TYJNT020NEBC | 38 | 13 | 5 | 4 | 1 | ¥ 17,700 |
| 1/4-18 NPT | TYJNT040NEBC | 38 | 18 | 8 | 5 | 2 | ¥ 17,700 |
| 3/8-18 NPT | TYMNT060NEBC | 50 | 22 | 8 | 5 | 2 | ¥ 28,500 [*] |
| 1/2-14 NPT | TYMNT080NEBC | 50 | 22 | 10 | 6 | 2 | ¥ 28,500 [*] |
| 3/4-14 NPT | TYRNT120NEBC | 63 | 24 | 10 | 6 | 3 | ¥ 74,500 [*] |
| 1 -11 1/2 NPT | TYUNT160NEBC | 75 | 30 | 13 | 6 | 3 | ¥ 133,000 [*] |
| 1 1/4-11 1/2 NPT | TYUNT200NEBC | 75 | 30 | 13.5 | 6 | 3 | ¥ 133,000 [*] |

* = Specified Distribution Items. Made to order products.