

Check Pin Series

「確かなねじ」のためには下穴管理が重要です!!
タップ下穴径の寸法を簡単に正確に確認できます!!

■ タップ下穴用チェックピン ■

切削タップ用下穴チェックピン

ロールタップ用下穴チェックピン

CPC-S

(ストレートタイプ)

CPC-T

(テーパタイプ)

CPR-S

(ストレートタイプ)

CPR-T

(テーパタイプ)



重要!

タップの下穴はチェックしてますか？

■ タップ下穴用チェックピン ■

CPC-S

切削タップ用下穴チェックピン
(ストレートタイプ)

HSS



CPC-T

切削タップ用下穴チェックピン
(テーパタイプ)

HSS



CPR-S

ロールタップ用下穴チェックピン
(ストレートタイプ)

HSS



CPR-T

ロールタップ用下穴チェックピン
(テーパタイプ)

HSS



■ 一般的なタップ加工工程



これ1本で、下穴の状態と下穴径を同時にチェックできます！！

完成したねじをチェック！
<https://www.yamawa.com/jp>で掲載中！

Step. 5

ねじ簡易
検査ツール

SIT
(止り用NB-6H)

Step. 1

位置決め&
面取り

ポイントドリル(PE-Q-V)



Step. 2

ドリリング

ドリル



Step. 3

下穴
仕上げ加工

リーマ



Step. 4

タッピング

タップ



Step. 5

ねじ簡易
検査ツール

SIT
(止り用NB-6H)



ここが
ポイント！



適正な
下穴

- タップの
寿命
アップ！
- めねじの
品質向上！

トータル コストダウン！



■ 下穴の状態をチェックしよう!

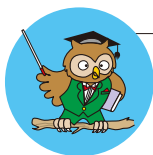

下穴が適正に加工されていない場合があります。



不具合例. **1**
— 曲がり —

チェックピンが途中で止まってしまう。

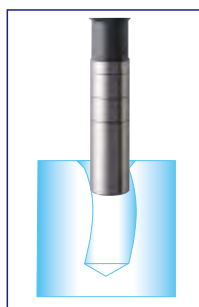

不具合例. **2**
— 倒れ —

ワーク端面に対して下穴が垂直ではない。

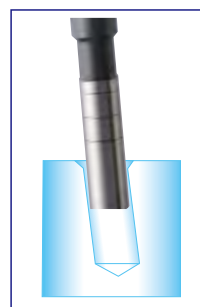

不具合例. **3**
— 口元拡大 —

口元が大きい。

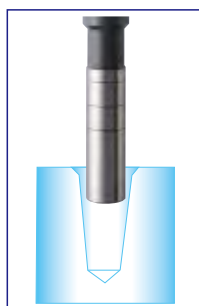

不具合例. **4**
— 径小 —

規格値の最小より小さな径になっている。

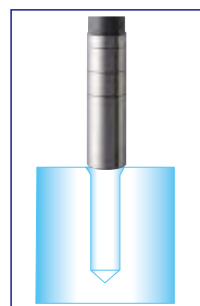

■ 下穴の不具合状況にてトラブル発生

- 1) 曲がった下穴
- 2) 倒れた下穴
- 3) 口元拡大した下穴
- 4) 径小の下穴 等



下穴を正常に加工し、下穴径を有利に設定することで、加工トラブルの軽減や寿命アップに結びつけることができます。タップの下穴についてチェックしてみましょう。

CPC-S

切削タップ用下穴チェックピン(ストレートタイプ)

HSS



特長

1. 5本セットにより数種類の下穴径チェックと下穴深さのチェックができます。
2. 耐摩耗性を考慮した高速度工具鋼を使用しています。
3. 通り穴及び止り穴のどちらにも使えます。

例: M12×1.75 (下穴径φ10.37)

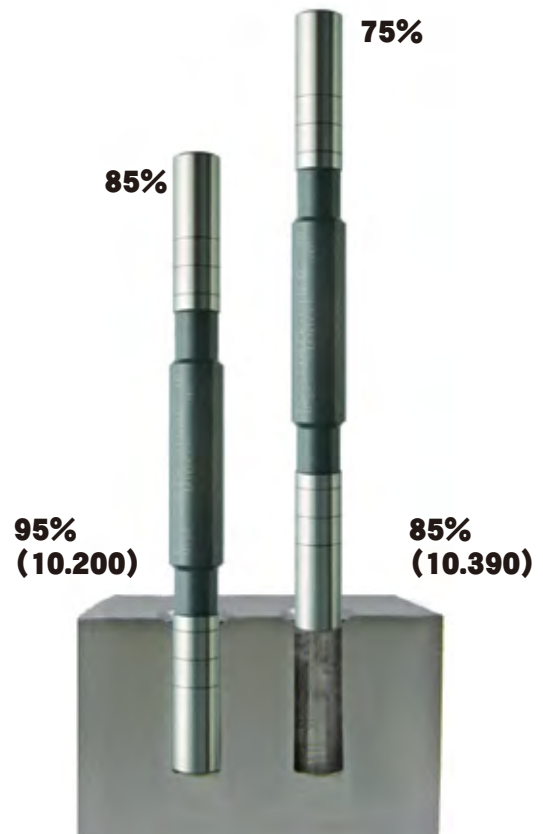

下穴径チェックピンの形状

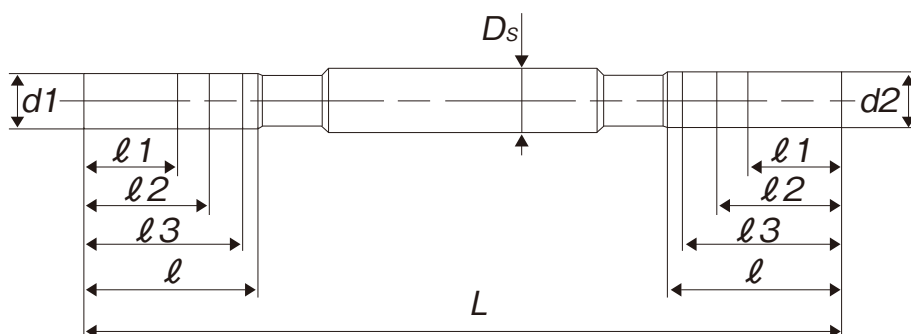

呼び	商品コード	L (mm)	ℓ (mm)	D _s (mm)	d1 (mm) (ひっかけり率)	d2 (mm) (ひっかけり率)	ℓ1 (mm) (1.5D)	ℓ2 (mm) (2D)	ℓ3 (mm) (2.5D)	メーカー希望 小売価格
M2 × 0.4	CPCS2.0EA	41.5	5.5	3.0	1.567 (100%)	1.610 (90%)	3.0	4.0	5.0	¥ 2,320
	CPCS2.0EB				1.589 (95%)	1.632 (85%)				¥ 2,320
	CPCS2.0EC				1.610 (90%)	1.654 (80%)				¥ 2,320
	CPCS2.0ED				1.632 (85%)	1.675 (75%)				¥ 2,320
	CPCS2.0EE				1.654 (80%)	1.697 (70%)				¥ 2,320
	CPCS2.0EF				1.675 (75%)	1.719 (65%)				¥ 2,320
	CPCS2.0ES				100%–70% (5本セット)					¥ 11,600
	CPCS2.0EM				95%–65% (5本セット)					¥ 11,600
M2.5 × 0.45	CPCS2.5FA	45	7.5	3.0	2.013 (100%)	2.062 (90%)	3.8	5.0	6.3	¥ 2,500
	CPCS2.5FB				2.037 (95%)	2.086 (85%)				¥ 2,500
	CPCS2.5FC				2.062 (90%)	2.110 (80%)				¥ 2,500
	CPCS2.5FD				2.086 (85%)	2.135 (75%)				¥ 2,500
	CPCS2.5FE				2.110 (80%)	2.159 (70%)				¥ 2,500
	CPCS2.5FF				2.135 (75%)	2.183 (65%)				¥ 2,500
	CPCS2.5FS				100%–70% (5本セット)					¥ 12,500
	CPCS2.5FM				95%–65% (5本セット)					¥ 12,500
M2.5 × 0.35	CPCS2.5DA	45	7.5	3.0	2.121 (100%)	2.159 (90%)	3.8	5.0	6.3	¥ 2,900
	CPCS2.5DB				2.140 (95%)	2.178 (85%)				¥ 2,900
	CPCS2.5DC				2.159 (90%)	2.197 (80%)				¥ 2,900
	CPCS2.5DD				2.178 (85%)	2.216 (75%)				¥ 2,900
	CPCS2.5DE				2.197 (80%)	2.235 (70%)				¥ 2,900
	CPCS2.5DF				2.216 (75%)	2.254 (65%)				¥ 2,900
	CPCS2.5DS				100%–70% (5本セット)					¥ 14,500
	CPCS2.5DM				95%–65% (5本セット)					¥ 14,500
M3 × 0.5	CPCS3.0GA	49	9.0	4.0	2.459 (100%)	2.513 (90%)	4.5	6.0	7.5	¥ 2,600
	CPCS3.0GB				2.486 (95%)	2.540 (85%)				¥ 2,600
	CPCS3.0GC				2.513 (90%)	2.567 (80%)				¥ 2,600
	CPCS3.0GD				2.540 (85%)	2.594 (75%)				¥ 2,600
	CPCS3.0GE				2.567 (80%)	2.621 (70%)				¥ 2,600
	CPCS3.0GF				2.594 (75%)	2.648 (65%)				¥ 2,600
	CPCS3.0GS				100%–70% (5本セット)					¥ 13,000
	CPCS3.0GM				95%–65% (5本セット)					¥ 13,000
M3 × 0.35	CPCS3.0DA	49	9.0	4.0	2.621 (100%)	2.659 (90%)	4.5	6.0	7.5	¥ 3,000
	CPCS3.0DB				2.640 (95%)	2.678 (85%)				¥ 3,000
	CPCS3.0DC				2.659 (90%)	2.697 (80%)				¥ 3,000
	CPCS3.0DD				2.678 (85%)	2.716 (75%)				¥ 3,000
	CPCS3.0DE				2.697 (80%)	2.735 (70%)				¥ 3,000
	CPCS3.0DF				2.716 (75%)	2.754 (65%)				¥ 3,000
	CPCS3.0DS				100%–70% (5本セット)					¥ 15,000
	CPCS3.0DM				95%–65% (5本セット)					¥ 15,000
M3.5 × 0.6	CPCS3.5HA	57	11.0	5.0	2.850 (100%)	2.915 (90%)	5.3	7.0	8.8	¥ 2,800
	CPCS3.5HB				2.883 (95%)	2.948 (85%)				¥ 2,800
	CPCS3.5HC				2.915 (90%)	2.980 (80%)				¥ 2,800
	CPCS3.5HD				2.948 (85%)	3.013 (75%)				¥ 2,800
	CPCS3.5HE				2.980 (80%)	3.045 (70%)				¥ 2,800
	CPCS3.5HF				3.013 (75%)	3.078 (65%)				¥ 2,800
	CPCS3.5HS				100%–70% (5本セット)					¥ 14,000
	CPCS3.5HM				95%–65% (5本セット)					¥ 14,000
M3.5 × 0.35	CPCS3.5DA	57	11.0	5.0	3.121 (100%)	3.159 (90%)	5.3	7.0	8.8	¥ 3,200
	CPCS3.5DB				3.140 (95%)	3.178 (85%)				¥ 3,200
	CPCS3.5DC				3.159 (90%)	3.197 (80%)				¥ 3,200
	CPCS3.5DD				3.178 (85%)	3.216 (75%)				¥ 3,200
	CPCS3.5DE				3.197 (80%)	3.235 (70%)				¥ 3,200
	CPCS3.5DF				3.216 (75%)	3.254 (65%)				¥ 3,200
	CPCS3.5DS				100%–70% (5本セット)					¥ 16,000
	CPCS3.5DM				95%–65% (5本セット)					¥ 16,000

呼び	商品コード	L (mm)	ℓ (mm)	D _s (mm)	d1 (mm) (ひっかけり率)	d2 (mm) (ひっかけり率)	ℓ1 (mm) (1.5D)	ℓ2 (mm) (2D)	ℓ3 (mm) (2.5D)	メーカー希望 小売価格
M4×0.7	CPCS4.0IA	57	11.0	5.0	3.242 (100%)	3.318 (90%)	6.0	8.0	10.0	¥ 2,800
	CPCS4.0IB				3.280 (95%)	3.356 (85%)				¥ 2,800
	CPCS4.0IC				3.318 (90%)	3.394 (80%)				¥ 2,800
	CPCS4.0ID				3.356 (85%)	3.432 (75%)				¥ 2,800
	CPCS4.0IE				3.394 (80%)	3.470 (70%)				¥ 2,800
	CPCS4.0IF				3.432 (75%)	3.507 (65%)				¥ 2,800
	CPCS4.0IS				100%–70% (5本セット)					¥ 14,000
	CPCS4.0IM				95%–65% (5本セット)					¥ 14,000
M4 ×0.5	CPCS4.0GA	57	11.0	5.0	3.459 (100%)	3.513 (90%)	6.0	8.0	10.0	¥ 3,200
	CPCS4.0GB				3.486 (95%)	3.540 (85%)				¥ 3,200
	CPCS4.0GC				3.513 (90%)	3.567 (80%)				¥ 3,200
	CPCS4.0GD				3.540 (85%)	3.594 (75%)				¥ 3,200
	CPCS4.0GE				3.567 (80%)	3.621 (70%)				¥ 3,200
	CPCS4.0GF				3.594 (75%)	3.648 (65%)				¥ 3,200
	CPCS4.0GS				100%–70% (5本セット)					¥ 16,000
	CPCS4.0GM				95%–65% (5本セット)					¥ 16,000
M4.5×0.75	CPCS4.5JA	65	14.0	5.5	3.688 (100%)	3.769 (90%)	6.8	9.0	11.3	¥ 3,300
	CPCS4.5JB				3.729 (95%)	3.810 (85%)				¥ 3,300
	CPCS4.5JC				3.769 (90%)	3.850 (80%)				¥ 3,300
	CPCS4.5JD				3.810 (85%)	3.891 (75%)				¥ 3,300
	CPCS4.5JE				3.850 (80%)	3.932 (70%)				¥ 3,300
	CPCS4.5JF				3.891 (75%)	3.972 (65%)				¥ 3,300
	CPCS4.5JS				100%–70% (5本セット)					¥ 16,500
	CPCS4.5JM				95%–65% (5本セット)					¥ 16,500
M4.5×0.5	CPCS4.5GA	65	14.0	5.5	3.959 (100%)	4.013 (90%)	6.8	9.0	11.3	¥ 3,300
	CPCS4.5GB				3.986 (95%)	4.040 (85%)				¥ 3,300
	CPCS4.5GC				4.013 (90%)	4.067 (80%)				¥ 3,300
	CPCS4.5GD				4.040 (85%)	4.094 (75%)				¥ 3,300
	CPCS4.5GE				4.067 (80%)	4.121 (70%)				¥ 3,300
	CPCS4.5GF				4.094 (75%)	4.148 (65%)				¥ 3,300
	CPCS4.5GS				100%–70% (5本セット)					¥ 16,500
	CPCS4.5GM				95%–65% (5本セット)					¥ 16,500
M5×0.8	CPCS5.0KA	65	14.0	5.5	4.134 (100%)	4.221 (90%)	7.5	10.0	12.5	¥ 2,900
	CPCS5.0KB				4.177 (95%)	4.264 (85%)				¥ 2,900
	CPCS5.0KC				4.221 (90%)	4.307 (80%)				¥ 2,900
	CPCS5.0KD				4.264 (85%)	4.350 (75%)				¥ 2,900
	CPCS5.0KE				4.307 (80%)	4.394 (70%)				¥ 2,900
	CPCS5.0KF				4.350 (75%)	4.437 (65%)				¥ 2,900
	CPCS5.0KS				100%–70% (5本セット)					¥ 14,500
	CPCS5.0KM				95%–65% (5本セット)					¥ 14,500
M5×0.5	CPCS5.0GA	65	14.0	5.5	4.459 (100%)	4.513 (90%)	7.5	10.0	12.5	¥ 3,400
	CPCS5.0GB				4.486 (95%)	4.540 (85%)				¥ 3,400
	CPCS5.0GC				4.513 (90%)	4.567 (80%)				¥ 3,400
	CPCS5.0GD				4.540 (85%)	4.594 (75%)				¥ 3,400
	CPCS5.0GE				4.567 (80%)	4.621 (70%)				¥ 3,400
	CPCS5.0GF				4.594 (75%)	4.648 (65%)				¥ 3,400
	CPCS5.0GS				100%–70% (5本セット)					¥ 17,000
	CPCS5.0GM				95%–65% (5本セット)					¥ 17,000
M6×1	CPCS6.0MA	73	16.5	6.0	4.917 (100%)	5.026 (90%)	9.0	12.0	15.0	¥ 3,200
	CPCS6.0MB				4.972 (95%)	5.080 (85%)				¥ 3,200
	CPCS6.0MC				5.026 (90%)	5.134 (80%)				¥ 3,200
	CPCS6.0MD				5.080 (85%)	5.188 (75%)				¥ 3,200
	CPCS6.0ME				5.134 (80%)	5.242 (70%)				¥ 3,200
	CPCS6.0MF				5.188 (75%)	5.296 (65%)				¥ 3,200
	CPCS6.0MS				100%–70% (5本セット)					¥ 16,000
	CPCS6.0MM				95%–65% (5本セット)					¥ 16,000

呼び	商品コード	L (mm)	ℓ (mm)	D _s (mm)	d1 (mm) (ひっかけり率)	d2 (mm) (ひっかけり率)	ℓ1 (mm) (1.5D)	ℓ2 (mm) (2D)	ℓ3 (mm) (2.5D)	メーカー希望 小売価格
M6×0.75	CPCS6.0JA	73	16.5	6.0	5.188 (100%)	5.269 (90%)	9.0	12.0	15.0	¥ 3,700
	CPCS6.0JB				5.229 (95%)	5.310 (85%)				¥ 3,700
	CPCS6.0JC				5.269 (90%)	5.350 (80%)				¥ 3,700
	CPCS6.0JD				5.310 (85%)	5.391 (75%)				¥ 3,700
	CPCS6.0JE				5.350 (80%)	5.432 (70%)				¥ 3,700
	CPCS6.0JF				5.391 (75%)	5.472 (65%)				¥ 3,700
	CPCS6.0JS				100%—70% (5本セット)					¥ 18,500
	CPCS6.0JM				95%—65% (5本セット)					¥ 18,500
M7×1	CPCS7.0MA	99	22.0	8.0	5.917 (100%)	6.026 (90%)	10.5	14.0	17.5	¥ 3,400
	CPCS7.0MB				5.972 (95%)	6.080 (85%)				¥ 3,400
	CPCS7.0MC				6.026 (90%)	6.134 (80%)				¥ 3,400
	CPCS7.0MD				6.080 (85%)	6.188 (75%)				¥ 3,400
	CPCS7.0ME				6.134 (80%)	6.242 (70%)				¥ 3,400
	CPCS7.0MF				6.188 (75%)	6.296 (65%)				¥ 3,400
	CPCS7.0MS				100%—70% (5本セット)					¥ 17,000
	CPCS7.0MM				95%—65% (5本セット)					¥ 17,000
M7×0.75	CPCS7.0JA	99	22.0	8.0	6.188 (100%)	6.269 (90%)	10.5	14.0	17.5	¥ 3,900
	CPCS7.0JB				6.229 (95%)	6.310 (85%)				¥ 3,900
	CPCS7.0JC				6.269 (90%)	6.350 (80%)				¥ 3,900
	CPCS7.0JD				6.310 (85%)	6.391 (75%)				¥ 3,900
	CPCS7.0JE				6.350 (80%)	6.432 (70%)				¥ 3,900
	CPCS7.0JF				6.391 (75%)	6.472 (65%)				¥ 3,900
	CPCS7.0JS				100%—70% (5本セット)					¥ 19,500
	CPCS7.0JM				95%—65% (5本セット)					¥ 19,500
M8×1.25	CPCS8.0NA	99	22.0	8.0	6.647 (100%)	6.782 (90%)	12.0	16.0	20.0	¥ 3,400
	CPCS8.0NB				6.714 (95%)	6.850 (85%)				¥ 3,400
	CPCS8.0NC				6.782 (90%)	6.917 (80%)				¥ 3,400
	CPCS8.0ND				6.850 (85%)	6.985 (75%)				¥ 3,400
	CPCS8.0NE				6.917 (80%)	7.053 (70%)				¥ 3,400
	CPCS8.0NF				6.985 (75%)	7.120 (65%)				¥ 3,400
	CPCS8.0NS				100%—70% (5本セット)					¥ 17,000
	CPCS8.0NM				95%—65% (5本セット)					¥ 17,000
M8×1	CPCS8.0MA	99	22.0	8.0	6.917 (100%)	7.026 (90%)	12.0	16.0	20.0	¥ 3,900
	CPCS8.0MB				6.972 (95%)	7.080 (85%)				¥ 3,900
	CPCS8.0MC				7.026 (90%)	7.134 (80%)				¥ 3,900
	CPCS8.0MD				7.080 (85%)	7.188 (75%)				¥ 3,900
	CPCS8.0ME				7.134 (80%)	7.242 (70%)				¥ 3,900
	CPCS8.0MF				7.188 (75%)	7.296 (65%)				¥ 3,900
	CPCS8.0MS				100%—70% (5本セット)					¥ 19,500
	CPCS8.0MM				95%—65% (5本セット)					¥ 19,500
M8×0.75	CPCS8.0JA	99	22.0	8.0	7.188 (100%)	7.269 (90%)	12.0	16.0	20.0	¥ 3,900
	CPCS8.0JB				7.229 (95%)	7.310 (85%)				¥ 3,900
	CPCS8.0JC				7.269 (90%)	7.350 (80%)				¥ 3,900
	CPCS8.0JD				7.310 (85%)	7.391 (75%)				¥ 3,900
	CPCS8.0JE				7.350 (80%)	7.432 (70%)				¥ 3,900
	CPCS8.0JF				7.391 (75%)	7.472 (65%)				¥ 3,900
	CPCS8.0JS				100%—70% (5本セット)					¥ 19,500
	CPCS8.0JM				95%—65% (5本セット)					¥ 19,500
M9×1.25	CPCS9.0NA	110	27.5	10.0	7.647 (100%)	7.782 (90%)	13.5	18.0	22.5	¥ 3,800
	CPCS9.0NB				7.714 (95%)	7.850 (85%)				¥ 3,800
	CPCS9.0NC				7.782 (90%)	7.917 (80%)				¥ 3,800
	CPCS9.0ND				7.850 (85%)	7.985 (75%)				¥ 3,800
	CPCS9.0NE				7.917 (80%)	8.053 (70%)				¥ 3,800
	CPCS9.0NF				7.985 (75%)	8.120 (65%)				¥ 3,800
	CPCS9.0NS				100%—70% (5本セット)					¥ 18,000
	CPCS9.0NM				95%—65% (5本セット)					¥ 18,000

呼び	商品コード	L (mm)	ℓ (mm)	D _s (mm)	d1 (mm) (ひっかけり率)	d2 (mm) (ひっかけり率)	ℓ1 ^(1.5D) (mm)	ℓ2 ^(2D) (mm)	ℓ3 ^(2.5D) (mm)	メーカー希望 小売価格
M9×1	CPCS9.0MA	110	27.5	10.0	7.917 (100%)	8.026 (90%)	13.5	18.0	22.5	¥ 4,200
	CPCS9.0MB				7.972 (95%)	8.080 (85%)				¥ 4,200
	CPCS9.0MC				8.026 (90%)	8.134 (80%)				¥ 4,200
	CPCS9.0MD				8.080 (85%)	8.188 (75%)				¥ 4,200
	CPCS9.0ME				8.134 (80%)	8.242 (70%)				¥ 4,200
	CPCS9.0MF				8.188 (75%)	8.296 (65%)				¥ 4,200
	CPCS9.0MS				100%–70% (5本セット)					¥ 21,000
	CPCS9.0MM				95%–65% (5本セット)					¥ 21,000
M9×0.75	CPCS9.0JA	110	27.5	10.0	8.188 (100%)	8.269 (90%)	13.5	18.0	22.5	¥ 4,200
	CPCS9.0JB				8.229 (95%)	8.310 (85%)				¥ 4,200
	CPCS9.0JC				8.269 (90%)	8.350 (80%)				¥ 4,200
	CPCS9.0JD				8.310 (85%)	8.391 (75%)				¥ 4,200
	CPCS9.0JE				8.350 (80%)	8.432 (70%)				¥ 4,200
	CPCS9.0JF				8.391 (75%)	8.472 (65%)				¥ 4,200
	CPCS9.0JS				100%–70% (5本セット)					¥ 21,000
	CPCS9.0JM				95%–65% (5本セット)					¥ 21,000
M10×1.5	CPCS0100A	110	27.5	10.0	8.376 (100%)	8.538 (90%)	15.0	20.0	25.0	¥ 3,500
	CPCS0100B				8.457 (95%)	8.620 (85%)				¥ 3,500
	CPCS0100C				8.538 (90%)	8.701 (80%)				¥ 3,500
	CPCS0100D				8.620 (85%)	8.782 (75%)				¥ 3,500
	CPCS0100E				8.701 (80%)	8.863 (70%)				¥ 3,500
	CPCS0100F				8.782 (75%)	8.944 (65%)				¥ 3,500
	CPCS0100S				100%–70% (5本セット)					¥ 17,500
	CPCS0100M				95%–65% (5本セット)					¥ 17,500
M10×1.25	CPCS010NA	110	27.5	10.0	8.647 (100%)	8.782 (90%)	15.0	20.0	25.0	¥ 4,100
	CPCS010NB				8.714 (95%)	8.850 (85%)				¥ 4,100
	CPCS010NC				8.782 (90%)	8.917 (80%)				¥ 4,100
	CPCS010ND				8.850 (85%)	8.985 (75%)				¥ 4,100
	CPCS010NE				8.917 (80%)	9.053 (70%)				¥ 4,100
	CPCS010NF				8.985 (75%)	9.120 (65%)				¥ 4,100
	CPCS010NS				100%–70% (5本セット)					¥ 20,500
	CPCS010NM				95%–65% (5本セット)					¥ 20,500
M10×1	CPCS010MA	110	27.5	10.0	8.917 (100%)	9.026 (90%)	15.0	20.0	25.0	¥ 4,100
	CPCS010MB				8.972 (95%)	9.080 (85%)				¥ 4,100
	CPCS010MC				9.026 (90%)	9.134 (80%)				¥ 4,100
	CPCS010MD				9.080 (85%)	9.188 (75%)				¥ 4,100
	CPCS010ME				9.134 (80%)	9.242 (70%)				¥ 4,100
	CPCS010MF				9.188 (75%)	9.296 (65%)				¥ 4,100
	CPCS010MS				100%–70% (5本セット)					¥ 20,500
	CPCS010MM				95%–65% (5本セット)					¥ 20,500
M10×0.75	CPCS010JA	110	27.5	10.0	9.188 (100%)	9.269 (90%)	15.0	20.0	25.0	¥ 4,100
	CPCS010JB				9.229 (95%)	9.310 (85%)				¥ 4,100
	CPCS010JC				9.269 (90%)	9.350 (80%)				¥ 4,100
	CPCS010JD				9.310 (85%)	9.391 (75%)				¥ 4,100
	CPCS010JE				9.350 (80%)	9.432 (70%)				¥ 4,100
	CPCS010JF				9.391 (75%)	9.472 (65%)				¥ 4,100
	CPCS010JS				100%–70% (5本セット)					¥ 20,500
	CPCS010JM				95%–65% (5本セット)					¥ 20,500
M11×1.5	CPCS0110A	121	33.0	12.0	9.376 (100%)	9.538 (90%)	16.5	22.0	27.5	¥ 3,900
	CPCS0110B				9.457 (95%)	9.620 (85%)				¥ 3,900
	CPCS0110C				9.538 (90%)	9.701 (80%)				¥ 3,900
	CPCS0110D				9.620 (85%)	9.782 (75%)				¥ 3,900
	CPCS0110E				9.701 (80%)	9.863 (70%)				¥ 3,900
	CPCS0110F				9.782 (75%)	9.944 (65%)				¥ 3,900
	CPCS0110S				100%–70% (5本セット)					¥ 19,500
	CPCS0110M				95%–65% (5本セット)					¥ 19,500

呼び	商品コード	L (mm)	ℓ (mm)	D _S (mm)	d1 (mm) (ひっかけり率)	d2 (mm) (ひっかけり率)	ℓ1 (mm) (1.5D)	ℓ2 (mm) (2D)	ℓ3 (mm) (2.5D)	メーカー希望 小売価格
M11×1	CPCS011MA	121	33.0	12.0	9.917 (100%)	10.026 (90%)	16.5	22.0	27.5	¥ 4,500
	CPCS011MB				9.972 (95%)	10.080 (85%)				¥ 4,500
	CPCS011MC				10.026 (90%)	10.134 (80%)				¥ 4,500
	CPCS011MD				10.080 (85%)	10.188 (75%)				¥ 4,500
	CPCS011ME				10.134 (80%)	10.242 (70%)				¥ 4,500
	CPCS011MF				10.134 (80%)	10.242 (70%)				¥ 4,500
	CPCS011MS				100%–70% (5本セット)					¥ 22,500
	CPCS011MM				95%–65% (5本セット)					¥ 22,500
M11×0.75	CPCS011JA	121	33.0	12.0	10.188 (100%)	10.269 (90%)	16.5	22.0	27.5	¥ 4,500
	CPCS011JB				10.229 (95%)	10.310 (85%)				¥ 4,500
	CPCS011JC				10.269 (90%)	10.350 (80%)				¥ 4,500
	CPCS011JD				10.310 (85%)	10.391 (75%)				¥ 4,500
	CPCS011JE				10.350 (80%)	10.432 (70%)				¥ 4,500
	CPCS011JF				10.391 (75%)	10.472 (65%)				¥ 4,500
	CPCS011JS				100%–70% (5本セット)					¥ 22,500
	CPCS011JM				95%–65% (5本セット)					¥ 22,500
M12×1.75	CPCS012PA	121	33.0	12.0	10.105 (100%)	10.295 (90%)	18.0	24.0	30.0	¥ 3,700
	CPCS012PB				10.200 (95%)	10.390 (85%)				¥ 3,700
	CPCS012PC				10.295 (90%)	10.484 (80%)				¥ 3,700
	CPCS012PD				10.390 (85%)	10.579 (75%)				¥ 3,700
	CPCS012PE				10.484 (80%)	10.674 (70%)				¥ 3,700
	CPCS012PF				10.579 (75%)	10.769 (65%)				¥ 3,700
	CPCS012PS				100%–70% (5本セット)					¥ 18,500
	CPCS012PM				95%–65% (5本セット)					¥ 18,500
M12×1.5	CPCS012OA	121	33.0	12.0	10.376 (100%)	10.538 (90%)	18.0	24.0	30.0	¥ 4,300
	CPCS012OB				10.457 (95%)	10.620 (85%)				¥ 4,300
	CPCS012OC				10.538 (90%)	10.701 (80%)				¥ 4,300
	CPCS012OD				10.620 (85%)	10.782 (75%)				¥ 4,300
	CPCS012OE				10.701 (80%)	10.863 (70%)				¥ 4,300
	CPCS012OF				10.782 (75%)	10.944 (65%)				¥ 4,300
	CPCS012OS				100%–70% (5本セット)					¥ 21,500
	CPCS012OM				95%–65% (5本セット)					¥ 21,500
M12×1.25	CPCS012NA	121	33.0	12.0	10.647 (100%)	10.782 (90%)	18.0	24.0	30.0	¥ 4,300
	CPCS012NB				10.714 (95%)	10.850 (85%)				¥ 4,300
	CPCS012NC				10.782 (90%)	10.917 (80%)				¥ 4,300
	CPCS012ND				10.850 (85%)	10.985 (75%)				¥ 4,300
	CPCS012NE				10.917 (80%)	11.053 (70%)				¥ 4,300
	CPCS012NF				10.985 (75%)	11.120 (65%)				¥ 4,300
	CPCS012NS				100%–70% (5本セット)					¥ 21,500
	CPCS012NM				95%–65% (5本セット)					¥ 21,500
M12×1	CPCS012MA	121	33.0	12.0	10.917 (100%)	11.026 (90%)	18.0	24.0	30.0	¥ 4,300
	CPCS012MB				10.972 (95%)	11.080 (85%)				¥ 4,300
	CPCS012MC				11.026 (90%)	11.134 (80%)				¥ 4,300
	CPCS012MD				11.080 (85%)	11.188 (75%)				¥ 4,300
	CPCS012ME				11.134 (80%)	11.242 (70%)				¥ 4,300
	CPCS012MF				11.188 (75%)	11.296 (65%)				¥ 4,300
	CPCS012MS				100%–70% (5本セット)					¥ 21,500
	CPCS012MM				95%–65% (5本セット)					¥ 21,500

CPC-S (ユニファイ用)

切削タップ用下穴チェックピン(ストレートタイプ)

HSS



下穴径チェックピンの形状

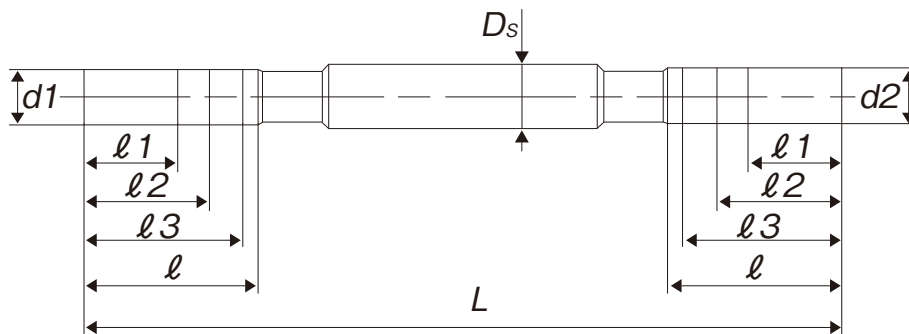

呼び	商品コード	L (mm)	l (mm)	D _s (mm)	d1 (mm) (ひっかけり率)	d2 (mm) (ひっかけり率)	l1 (mm) (1.5D)	l2 (mm) (2D)	l3 (mm) (2.5D)	メーカー希望 小売価格
No.2-56UNC	CPCSUN2EA	41.5	5.5	3	1.695 (100%)	1.742 (90%)	3.3	4.4	5.5	¥ 2,700
	CPCSUN2EB				1.718 (95%)	1.767 (85%)				¥ 2,700
	CPCSUN2EC				1.742 (90%)	1.791 (80%)				¥ 2,700
	CPCSUN2ED				1.767 (85%)	1.816 (75%)				¥ 2,700
	CPCSUN2EE				1.791 (80%)	1.840 (70%)				¥ 2,700
	CPCSUN2ES				100%-70% (5本セット)					¥ 13,500
	CPCSUN2EM				95%-65% (5本セット)					¥ 13,500
No.2-64UNF	CPCSUN2DA	41.5	5.5	3	1.756 (100%)	1.797 (90%)	3.3	4.4	5.5	¥ 2,700
	CPCSUN2DB				1.776 (95%)	1.819 (85%)				¥ 2,700
	CPCSUN2DC				1.797 (90%)	1.840 (80%)				¥ 2,700
	CPCSUN2DD				1.819 (85%)	1.862 (75%)				¥ 2,700
	CPCSUN2DE				1.840 (80%)	1.883 (70%)				¥ 2,700
	CPCSUN2DS				100%-70% (5本セット)					¥ 13,500
	CPCSUN2DM				95%-65% (5本セット)					¥ 13,500

呼び	商品コード	L (mm)	ℓ (mm)	D _s (mm)	d1 (mm) (ひっかけり率)	d2 (mm) (ひっかけり率)	ℓ1 ^(1.5D) (mm)	ℓ2 ^(2D) (mm)	ℓ3 ^(2.5D) (mm)	メーカー希望 小売価格
No.3-48UNC	CPCSUN3FA	45	7.5	3	1.941 (100%)	1.999 (90%)	3.8	5.0	6.3	¥ 2,900
	CPCSUN3FB				1.971 (95%)	2.028 (85%)				¥ 2,900
	CPCSUN3FC				1.999 (90%)	2.057 (80%)				¥ 2,900
	CPCSUN3FD				2.028 (85%)	2.085 (75%)				¥ 2,900
	CPCSUN3FE				2.057 (80%)	2.114 (70%)				¥ 2,900
	CPCSUN3FS				100%–70% (5本セット)					¥ 14,500
	CPCSUN3FM				95%–65% (5本セット)					¥ 14,500
No.3-56UNF	CPCSUN3EA	45	7.5	3	2.025 (100%)	2.073 (90%)	3.8	5.0	6.3	¥ 2,900
	CPCSUN3EB				2.049 (95%)	2.098 (85%)				¥ 2,900
	CPCSUN3EC				2.073 (90%)	2.122 (80%)				¥ 2,900
	CPCSUN3ED				2.098 (85%)	2.147 (75%)				¥ 2,900
	CPCSUN3EE				2.122 (80%)	2.171 (70%)				¥ 2,900
	CPCSUN3ES				100%–70% (5本セット)					¥ 14,500
	CPCSUN3EM				95%–65% (5本セット)					¥ 14,500
No.4-40UNC	CPCSUN4HA	45	7.5	3	2.157 (100%)	2.226 (90%)	4.3	5.7	7.1	¥ 3,000
	CPCSUN4HB				2.192 (95%)	2.261 (85%)				¥ 3,000
	CPCSUN4HC				2.226 (90%)	2.295 (80%)				¥ 3,000
	CPCSUN4HD				2.261 (85%)	2.329 (75%)				¥ 3,000
	CPCSUN4HE				2.295 (80%)	2.364 (70%)				¥ 3,000
	CPCSUN4HS				100%–70% (5本セット)					¥ 15,000
	CPCSUN4HM				95%–65% (5本セット)					¥ 15,000
No.4-48UNF	CPCSUN4FA	45	7.5	3	2.271 (100%)	2.329 (90%)	4.3	5.7	7.1	¥ 3,000
	CPCSUN4FB				2.301 (95%)	2.358 (85%)				¥ 3,000
	CPCSUN4FC				2.329 (90%)	2.387 (80%)				¥ 3,000
	CPCSUN4FD				2.358 (85%)	2.415 (75%)				¥ 3,000
	CPCSUN4FE				2.387 (80%)	2.444 (70%)				¥ 3,000
	CPCSUN4FS				100%–70% (5本セット)					¥ 15,000
	CPCSUN4FM				95%–65% (5本セット)					¥ 15,000
No.5-40UNC	CPCSUN5HA	49	9	4	2.487 (100%)	2.556 (90%)	4.8	6.4	7.9	¥ 3,100
	CPCSUN5HB				2.522 (95%)	2.591 (85%)				¥ 3,100
	CPCSUN5HC				2.556 (90%)	2.625 (80%)				¥ 3,100
	CPCSUN5HD				2.591 (85%)	2.659 (75%)				¥ 3,100
	CPCSUN5HE				2.625 (80%)	2.694 (70%)				¥ 3,100
	CPCSUN5HS				100%–70% (5本セット)					¥ 15,500
	CPCSUN5HM				95%–65% (5本セット)					¥ 15,500
No.5-44UNF	CPCSUN5GA	49	9	4	2.551 (100%)	2.613 (90%)	4.8	6.4	7.9	¥ 3,100
	CPCSUN5GB				2.581 (95%)	2.644 (85%)				¥ 3,100
	CPCSUN5GC				2.613 (90%)	2.675 (80%)				¥ 3,100
	CPCSUN5GD				2.644 (85%)	2.706 (75%)				¥ 3,100
	CPCSUN5GE				2.675 (80%)	2.738 (70%)				¥ 3,100
	CPCSUN5GS				100%–70% (5本セット)					¥ 15,500
	CPCSUN5GM				95%–65% (5本セット)					¥ 15,500
No.6-32UNC	CPCSUN6JA	49	9	4	2.642 (100%)	2.732 (90%)	5.3	7.0	8.8	¥ 3,200
	CPCSUN6JB				2.689 (95%)	2.775 (85%)				¥ 3,200
	CPCSUN6JC				2.732 (90%)	2.818 (80%)				¥ 3,200
	CPCSUN6JD				2.775 (85%)	2.861 (75%)				¥ 3,200
	CPCSUN6JE				2.818 (80%)	2.903 (70%)				¥ 3,200
	CPCSUN6JS				100%–70% (5本セット)					¥ 16,000
	CPCSUN6JM				95%–65% (5本セット)					¥ 16,000
No.6-40UNF	CPCSUN6HA	49	9	4	2.820 (100%)	2.886 (90%)	5.3	7.0	8.8	¥ 3,200
	CPCSUN6HB				2.852 (95%)	2.921 (85%)				¥ 3,200
	CPCSUN6HC				2.886 (90%)	2.955 (80%)				¥ 3,200
	CPCSUN6HD				2.921 (85%)	2.989 (75%)				¥ 3,200
	CPCSUN6HE				2.955 (80%)	3.024 (70%)				¥ 3,200
	CPCSUN6HS				100%–70% (5本セット)					¥ 16,000
	CPCSUN6HM				95%–65% (5本セット)					¥ 16,000

呼び	商品コード	L (mm)	ℓ (mm)	D _S (mm)	d1 (mm) (ひっかけり率)	d2 (mm) (ひっかけり率)	ℓ1 (mm) (1.5D)	ℓ2 (mm) (2D)	ℓ3 (mm) (2.5D)	メーカー希望 小売価格
No.8-32UNC	CPCSUN8JA	57	11	5	3.302 (100%)	3.394 (90%)	6.3	8.3	10.4	¥ 3,300
	CPCSUN8JB				3.351 (95%)	3.437 (85%)				¥ 3,300
	CPCSUN8JC				3.394 (90%)	3.480 (80%)				¥ 3,300
	CPCSUN8JD				3.437 (85%)	3.523 (75%)				¥ 3,300
	CPCSUN8JE				3.480 (80%)	3.565 (70%)				¥ 3,300
	CPCSUN8JS				100%–70% (5本セット)					¥ 16,500
	CPCSUN8JM				95%–65% (5本セット)					¥ 16,500
No.8-36UNF	CPCSUN8IA	57	11	5	3.404 (100%)	3.480 (90%)	6.3	8.3	10.4	¥ 3,300
	CPCSUN8IB				3.441 (95%)	3.518 (85%)				¥ 3,300
	CPCSUN8IC				3.480 (90%)	3.556 (80%)				¥ 3,300
	CPCSUN8ID				3.518 (85%)	3.594 (75%)				¥ 3,300
	CPCSUN8IE				3.556 (80%)	3.632 (70%)				¥ 3,300
	CPCSUN8IS				100%–70% (5本セット)					¥ 16,500
	CPCSUN8IM				95%–65% (5本セット)					¥ 16,500
No.10-24UNC	CPCSUNAMA	65	14	5.5	3.683 (100%)	3.795 (90%)	7.2	9.7	12.1	¥ 3,400
	CPCSUNAMB				3.738 (95%)	3.852 (85%)				¥ 3,400
	CPCSUNAMC				3.795 (90%)	3.909 (80%)				¥ 3,400
	CPCSUNAMD				3.852 (85%)	3.967 (75%)				¥ 3,400
	CPCSUNAME				3.909 (80%)	4.024 (70%)				¥ 3,400
	CPCSUNAMS				100%–70% (5本セット)					¥ 17,000
	CPCSUNAMM				95%–65% (5本セット)					¥ 17,000
No.10-32UNF	CPCSUNAJA	65	14	5.5	3.963 (100%)	4.053 (90%)	7.2	9.7	12.1	¥ 3,400
	CPCSUNAJB				4.010 (95%)	4.096 (85%)				¥ 3,400
	CPCSUNAJC				4.053 (90%)	4.139 (80%)				¥ 3,400
	CPCSUNAJD				4.096 (85%)	4.182 (75%)				¥ 3,400
	CPCSUNAJE				4.139 (80%)	4.224 (70%)				¥ 3,400
	CPCSUNAJS				100%–70% (5本セット)					¥ 17,000
	CPCSUNAJM				95%–65% (5本セット)					¥ 17,000
No.12-24UNC	CPCSUNCMA	65	14	5.5	4.344 (100%)	4.455 (90%)	8.2	11.0	13.7	¥ 3,800
	CPCSUNCMB				4.398 (95%)	4.512 (85%)				¥ 3,800
	CPCSUNCMC				4.455 (90%)	4.569 (80%)				¥ 3,800
	CPCSUNCMD				4.512 (85%)	4.627 (75%)				¥ 3,800
	CPCSUNCME				4.569 (80%)	4.684 (70%)				¥ 3,800
	CPCSUNCMS				100%–70% (5本セット)					¥ 19,000
	CPCSUNCMM				95%–65% (5本セット)					¥ 19,000
No.12-28UNF	CPCSUNCKA	65	14	5.5	4.496 (100%)	4.602 (90%)	8.2	11.0	13.7	¥ 3,800
	CPCSUNCKB				4.553 (95%)	4.651 (85%)				¥ 3,800
	CPCSUNCKC				4.602 (90%)	4.700 (80%)				¥ 3,800
	CPCSUNCKD				4.651 (85%)	4.749 (75%)				¥ 3,800
	CPCSUNCKE				4.700 (80%)	4.799 (70%)				¥ 3,800
	CPCSUNCKS				100%–70% (5本セット)					¥ 19,000
	CPCSUNCKM				95%–65% (5本セット)					¥ 19,000
1/4-20UNC	CPCSU04NA	73	16.5	6	4.979 (100%)	5.113 (90%)	9.5	12.7	15.9	¥ 3,900
	CPCSU04NB				5.044 (95%)	5.181 (85%)				¥ 3,900
	CPCSU04NC				5.113 (90%)	5.250 (80%)				¥ 3,900
	CPCSU04ND				5.181 (85%)	5.319 (75%)				¥ 3,900
	CPCSU04NE				5.250 (80%)	5.388 (70%)				¥ 3,900
	CPCSU04NS				100%–70% (5本セット)					¥ 19,500
	CPCSU04NM				95%–65% (5本セット)					¥ 19,500
1/4-28UNF	CPCSU04KA	73	16.5	6	5.360 (100%)	5.466 (90%)	9.5	12.7	15.9	¥ 3,900
	CPCSU04KB				5.417 (95%)	5.515 (85%)				¥ 3,900
	CPCSU04KC				5.466 (90%)	5.564 (80%)				¥ 3,900
	CPCSU04KD				5.515 (85%)	5.613 (75%)				¥ 3,900
	CPCSU04KE				5.564 (80%)	5.663 (70%)				¥ 3,900
	CPCSU04KS				100%–70% (5本セット)					¥ 19,500
	CPCSU04KM				95%–65% (5本セット)					¥ 19,500

呼び	商品コード	L (mm)	ℓ (mm)	D _s (mm)	d1 (mm) (ひっかけり率)	d2 (mm) (ひっかけり率)	ℓ1 (mm) (1.5D)	ℓ2 (mm) (2D)	ℓ3 (mm) (2.5D)	メーカー希望 小売価格
5/16-18UNC	CPCSU050A	99	22	8	6.401 (100%)	6.563 (90%)	11.9	15.9	19.8	¥ 4,000
	CPCSU050B				6.487 (95%)	6.639 (85%)				¥ 4,000
	CPCSU050C				6.563 (90%)	6.716 (80%)				¥ 4,000
	CPCSU050D				6.639 (85%)	6.792 (75%)				¥ 4,000
	CPCSU050E				6.716 (80%)	6.869 (70%)				¥ 4,000
	CPCSU050S				100%—70% (5本セット)					¥ 20,000
	CPCSU050M				95%—65% (5本セット)					¥ 20,000
5/16-24UNF	CPCSU05MA	99	22	8	6.782 (100%)	6.907 (90%)	11.9	15.9	19.8	¥ 4,000
	CPCSU05MB				6.850 (95%)	6.964 (85%)				¥ 4,000
	CPCSU05MC				6.907 (90%)	7.021 (80%)				¥ 4,000
	CPCSU05MD				6.964 (85%)	7.079 (75%)				¥ 4,000
	CPCSU05ME				7.021 (80%)	7.136 (70%)				¥ 4,000
	CPCSU05MS				100%—70% (5本セット)					¥ 20,000
	CPCSU05MM				95%—65% (5本セット)					¥ 20,000
3/8-16UNC	CPCSU06PA	110	27.5	10	7.798 (100%)	7.978 (90%)	14.3	19.1	23.8	¥ 4,200
	CPCSU06PB				7.892 (95%)	8.064 (85%)				¥ 4,200
	CPCSU06PC				7.978 (90%)	8.150 (80%)				¥ 4,200
	CPCSU06PD				8.064 (85%)	8.236 (75%)				¥ 4,200
	CPCSU06PE				8.150 (80%)	8.322 (70%)				¥ 4,200
	CPCSU06PS				100%—70% (5本セット)					¥ 21,000
	CPCSU06PM				95%—65% (5本セット)					¥ 21,000
3/8-24UNF	CPCSU06MA	110	27.5	10	8.382 (100%)	8.494 (90%)	14.3	19.1	23.8	¥ 4,200
	CPCSU06MB				8.437 (95%)	8.551 (85%)				¥ 4,200
	CPCSU06MC				8.494 (90%)	8.608 (80%)				¥ 4,200
	CPCSU06MD				8.551 (85%)	8.666 (75%)				¥ 4,200
	CPCSU06ME				8.608 (80%)	8.723 (70%)				¥ 4,200
	CPCSU06MS				100%—70% (5本セット)					¥ 21,000
	CPCSU06MM				95%—65% (5本セット)					¥ 21,000
7/16-14UNC	CPCSU07QA	121	33	12	9.144 (100%)	9.345 (90%)	16.7	22.2	27.8	¥ 4,300
	CPCSU07QB				9.247 (95%)	9.443 (85%)				¥ 4,300
	CPCSU07QC				9.345 (90%)	9.542 (80%)				¥ 4,300
	CPCSU07QD				9.443 (85%)	9.640 (75%)				¥ 4,300
	CPCSU07QE				9.542 (80%)	9.738 (70%)				¥ 4,300
	CPCSU07QS				100%—70% (5本セット)					¥ 21,500
	CPCSU07QM				95%—65% (5本セット)					¥ 21,500
7/16-20UNF	CPCSU07NA	121	33	12	9.729 (100%)	9.876 (90%)	16.7	22.2	27.8	¥ 4,300
	CPCSU07NB				9.807 (95%)	9.944 (85%)				¥ 4,300
	CPCSU07NC				9.876 (90%)	10.013 (80%)				¥ 4,300
	CPCSU07ND				9.944 (85%)	10.082 (75%)				¥ 4,300
	CPCSU07NE				10.013 (80%)	10.151 (70%)				¥ 4,300
	CPCSU07NS				100%—70% (5本セット)					¥ 21,500
	CPCSU07NM				95%—65% (5本セット)					¥ 21,500
1/2-13UNC	CPCSU08RA	121	33	12	10.592 (100%)	10.796 (90%)	19.1	25.4	31.8	¥ 4,500
	CPCSU08RB				10.691 (95%)	10.902 (85%)				¥ 4,500
	CPCSU08RC				10.796 (90%)	11.008 (80%)				¥ 4,500
	CPCSU08RD				10.902 (85%)	11.114 (75%)				¥ 4,500
	CPCSU08RE				11.008 (80%)	11.219 (70%)				¥ 4,500
	CPCSU08RS				100%—70% (5本セット)					¥ 22,500
	CPCSU08RM				95%—65% (5本セット)					¥ 22,500
1/2-20UNF	CPCSU08NA	121	33	12	11.329 (100%)	11.463 (90%)	19.1	25.4	31.8	¥ 4,500
	CPCSU08NB				11.394 (95%)	11.531 (85%)				¥ 4,500
	CPCSU08NC				11.463 (90%)	11.600 (80%)				¥ 4,500
	CPCSU08ND				11.531 (85%)	11.669 (75%)				¥ 4,500
	CPCSU08NE				11.600 (80%)	11.738 (70%)				¥ 4,500
	CPCSU08NS				100%—70% (5本セット)					¥ 22,500
	CPCSU08NM				95%—65% (5本セット)					¥ 22,500

CPC-T

切削タップ用下穴チェックピン(テーパタイプ) HSS

HSS



特長

1. 1本で下穴径の簡易チェックができます。
2. 耐摩耗性を考慮した高速度工具鋼を使用しています。
3. 通り穴または下穴底と下穴チェックピンが干渉しない深さの止り穴のどちらにも使えます。

下穴径φ10.37チェック例



下穴径チェックピンの形状

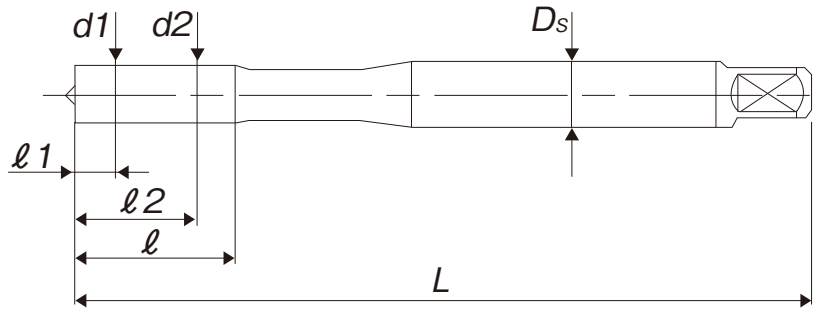

呼び	商品コード	L (mm)	l (mm)	Ds (mm)	d1 (mm) (ひっかけり率)	d2 (mm) (ひっかけり率)	(l1) (mm)	(l2) (mm)	メーカー希望小売価格
M2×0.4	CPCT2.0E	42	7	3	1.567 (100%)	1.679 (74%)	1	6	¥ 1,500
M2.5×0.45	CPCT2.5F	46	8	3	2.013 (100%)	2.138 (74%)	1.5	6.5	¥ 1,600
M3×0.5	CPCT3.0G	46	8.5	4	2.459 (100%)	2.599 (74%)	1.5	7	¥ 1,700
M4×0.7	CPCT4.0I	52	11	5	3.242 (100%)	3.422 (76%)	2.3	8.3	¥ 1,900
M5×0.8	CPCT5.0K	59.5	13	5.5	4.134 (100%)	4.334 (77%)	2.5	10	¥ 1,900
M6×1	CPCT6.0M	61.5	17	6	4.917 (100%)	5.153 (78%)	3.8	12.8	¥ 2,100
M8×1.25	CPCT8.0N	90	19	8	6.647 (100%)	6.912 (80%)	4.7	14.7	¥ 2,400
M10×1.5	CPCT0100	100	23	10	8.376 (100%)	8.676 (82%)	6.7	16.7	¥ 2,400
M12×1.75	CPCT012P	110	27	12	10.106 (100%)	10.441 (82%)	7.7	19.7	¥ 2,500

※M2～M6は先端平になります。

■ 下穴径をチェックしよう!



切削タップ用下穴チェックピンを使って実際に
M6×1 6Hめねじの下穴径を確認してみましょう!

CPC-S(ストレートタイプ)ご使用例

Step. 1 M6×1 6Hめねじ内径規格を調べます。Min. 4.917 Max. 5.153

Step. 2 M6×1下穴チェックピンサイズ

呼び	商品コード	L (mm)	ℓ (mm)	Ds (mm)	d1 (mm) (ひっかけり率)	d2 (mm) (ひっかけり率)
M6×1	CPCS6.0MA	73	16.5	6	4.917 (100%)	5.026 (90%)
	CPCS6.0MB				4.972 (95%)	5.080 (85%)
	CPCS6.0MC				5.026 (90%)	5.134 (80%)
	CPCS6.0MD				5.080 (85%)	5.188 (75%)
	CPCS6.0ME				5.134 (80%)	5.242 (70%)

左記の表から6Hめねじ内径に
もっとも最大、最小に近いピンを選定します。

⇒ ①4.917(100%)と②5.134(80%)

※被削材の特性によっては、ねじ下穴径を許される範囲
で大きくすることにより、ねじ立てが有利となります。

Step. 3 実際にStep.2で選んだ①と②のチェックピンを挿入してみます。

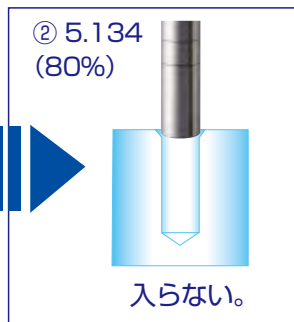

CPC-T(テーパタイプ)ご使用例

呼び	商品コード	L (mm)	ℓ (mm)	Ds (mm)	d1 (mm) (ひっかけり率)	d2 (mm) (ひっかけり率)	(ℓ1) (mm)	(ℓ2) (mm)	メーカー希望 小売価格
M6×1	CPCT6.0M	61.5	17	6	4.917(100%)	5.153(78%)	3.8	12.8	¥ 2,100

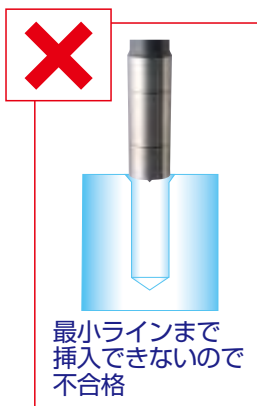

詳しい使い方 (動画) はこちら!



CPR-S

ロールタップ用下穴チェックピン(ストレートタイプ)

HSS



特長

1. 数種類の下穴径チェックと下穴深さのチェックができます。
2. 耐摩耗性を考慮した高速度工具鋼を使用しています。
3. 通り穴及び止り穴のどちらにも使えます。

下穴径チェックピンの形状

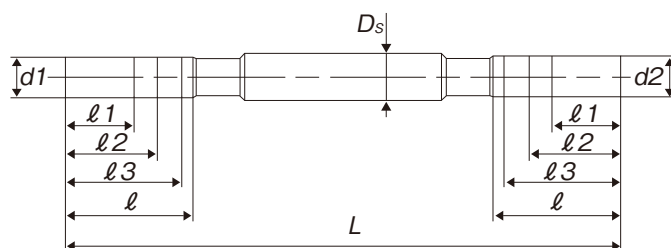

呼び	商品コード	L (mm)	l (mm)	D _s (mm)	d1 (mm)	d2 (mm)	l1 (mm)	l2 (mm)	l3 (mm)	メーカー希望 小売価格
M2×0.4	CPRS2.0E	41.5	5.5	3	1.790	1.840	3	4	5	¥ 2,320
M2.5×0.45	CPRS2.5F	41.5	5.5	3	2.270	2.340	3.75	5	6.25	¥ 2,500
M2.6×0.45	CPRS2.6F	41.5	5.5	3	2.370	2.440	3.9	5.2	6.5	¥ 2,500
M3×0.5	CPRS3.0G	49	9	4	2.750	2.820	4.5	6	7.5	¥ 2,600
M4×0.7	CPRS4.0I	57	11	5	3.650	3.720	6	8	10	¥ 2,800
M5×0.8	CPRS5.0K	65	14	5.5	4.590	4.670	7.5	10	12.5	¥ 2,900
M6×1	CPRS6.0M	73	16.5	6	5.490	5.590	9	12	5	¥ 3,200
M8×1.25	CPRS8.0N	99	22	8	7.360	7.490	12	16	20	¥ 3,400
M10×1.5	CPRS0100	110	27.5	10	9.220	9.340	15	20	25	¥ 3,500
M10×1.25	CPRS010N	110	27.5	10	9.350	9.490	15	20	25	¥ 4,100
M12×1.75	CPRS012P	121	33	12	11.090	11.230	18	24	30	¥ 3,700
M12×1.5	CPRS012O	121	33	12	11.220	11.340	18	24	30	¥ 4,300
M12×1.25	CPRS012N	121	33	12	11.360	11.500	18	24	30	¥ 4,300

呼び	商品コード	L (mm)	ℓ (mm)	D _s (mm)	d1 (mm)	d2 (mm)	ℓ1 (mm)	ℓ2 (mm)	ℓ3 (mm)	メーカー希望 小売価格
No.2-56UNC	CPRSUN2E	41.5	5.5	3	1.960	2.040	3.3	4.4	5.5	¥ 2,700
No.2-64UNF	CPRSUN2D	41.5	5.5	3	1.980	2.060	3.3	4.4	5.5	¥ 2,700
No.3-48UNC	CPRSUN3F	45	7.5	3	2.250	2.350	3.8	5.0	6.3	¥ 2,900
No.3-56UNF	CPRSUN3E	45	7.5	3	2.290	2.370	3.8	5.0	6.3	¥ 2,900
No.4-40UNC	CPRSUN4H	49	9	4	2.540	2.640	4.3	5.7	7.1	¥ 3,000
No.4-48UNF	CPRSUN4F	49	9	4	2.590	2.680	4.3	5.7	7.1	¥ 3,000
No.5-40UNC	CPRSUN5H	49	9	4	2.870	2.970	4.8	6.4	7.9	¥ 3,100
No.5-44UNF	CPRSUN5G	49	9	4	2.900	2.990	4.8	6.4	7.9	¥ 3,100
No.6-32UNC	CPRSUN6J	57	11	5	3.110	3.220	5.3	7.0	8.8	¥ 3,200
No.6-40UNF	CPRSUN6H	57	11	5	3.190	3.290	5.3	7.0	8.8	¥ 3,200
No.8-32UNC	CPRSUN8J	57	11	5	3.780	3.890	6.3	8.3	10.4	¥ 3,300
No.8-36UNF	CPRSUN8I	57	11	5	3.810	3.910	6.3	8.3	10.4	¥ 3,300
No.10-24UNC	CPRSUNAM	65	14	5.5	4.300	4.440	7.2	9.7	12.1	¥ 3,400
No.10-32UNF	CPRSUNAJ	65	14	5.5	4.440	4.530	7.2	9.7	12.1	¥ 3,400
No.12-24UNC	CPRSUNCM	73	16.5	6	4.960	5.070	8.2	11	13.7	¥ 3,800
No.12-28UNF	CPRSUNCK	73	16.5	6	5.030	5.130	8.2	11	13.7	¥ 3,800
1/4-20UNC	CPRSU04N	73	16.5	6	5.730	5.860	9.5	12.7	15.9	¥ 3,900
1/4-28UNF	CPRSU04K	73	16.5	6	5.910	6.000	9.5	12.7	15.9	¥ 3,900
5/16-18UNC	CPRSU05O	99	22	8	7.230	7.380	12	16	20	¥ 4,000
5/16-24UNF	CPRSU05M	99	22	8	7.420	7.530	12	16	20	¥ 4,000
3/8-16UNC	CPRSU06P	110	27.5	10	8.720	8.890	14.3	19.1	23.8	¥ 4,200
3/8-24UNF	CPRSU06M	110	27.5	10	8.990	9.100	14.3	19.1	23.8	¥ 4,200
7/16-14UNC	CPRSU07O	121	33	12	10.200	10.400	16.7	22.2	27.8	¥ 4,300
7/16-20UNF	CPRSU07N	121	33	12	10.480	10.620	16.7	22.2	27.8	¥ 4,300
1/2-13UNC	CPRSU08R	110	33	12	11.700	11.920	19.1	25.4	31.8	¥ 4,500
1/2-20UNF	CPRSU08N	110	33	12	12.060	12.200	19.1	25.4	31.8	¥ 4,500

CPR-T

ロールタップ用下穴チェックピン(テーパタイプ)

HSS

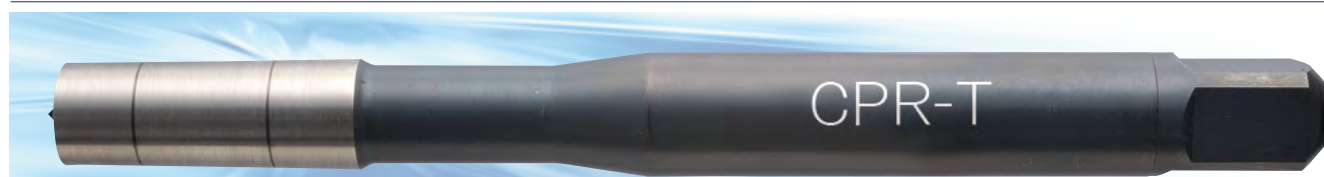

特長

1. 1本で下穴径の簡易チェックができます。
2. 耐摩耗性を考慮した高速度工具鋼を使用しています。
3. 通り穴または下穴径と下穴チェックピンが干渉しない深さの止り穴のどちらにも使えます。

下穴径チェックピンの形状

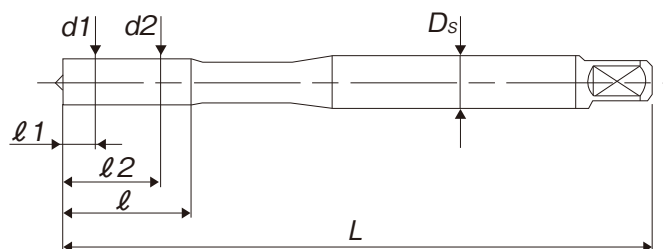

呼び	商品コード	L (mm)	l (mm)	Ds (mm)	d1 (mm)	d2 (mm)	l1 (mm)	l2 (mm)	メーカー希望小売価格
M2×0.4	CPRT2.0E	42	7	3	1.790	1.840	1	6	¥ 1,500
M2.5×0.45	CPRT2.5F	46	8	3	2.270	2.340	1.5	6.5	¥ 1,600
M2.6×0.45	CPRT2.6F	46	8	4	2.370	2.440	1.5	6.5	¥ 1,600
M3×0.5	CPRT3.0G	46	8.5	4	2.750	2.820	1.5	7	¥ 1,700
M4×0.7	CPRT4.0I	52	10.5	5	3.650	3.720	2.3	8.3	¥ 1,900
M5×0.8	CPRT5.0K	59.5	12.5	5.5	4.590	4.670	2.5	10	¥ 1,900
M6×1	CPRT6.0M	61.5	16.5	6	5.490	5.590	3.8	12.8	¥ 2,100
M8×1.25	CPRT8.0N	90	19.4	8	7.360	7.490	4.7	14.7	¥ 2,400
M10×1.5	CPRT0100	100	23.4	10	9.220	9.340	6.7	16.7	¥ 2,400
M10×1.25	CPRT010N	100	23.4	10	9.350	9.490	6.7	16.7	¥ 2,800
M12×1.75	CPRT012P	110	27.4	12	11.090	11.230	7.7	19.7	¥ 2,500
M12×1.5	CPRT0120	110	27.4	12	11.220	11.340	7.7	19.7	¥ 2,900
M12×1.25	CPRT012N	110	27.4	12	11.360	11.500	7.7	19.7	¥ 2,900

呼び	商品コード	L (mm)	ℓ (mm)	Ds (mm)	d1 (mm)	d2 (mm)	ℓ1 (mm)	ℓ2 (mm)	メーカー希望 小売価格
No.2-56UNC	CPRTUN2E	46	8	3	1.960	2.040	1.5	6.5	¥ 1,800
No.2-64UNF	CPRTUN2D	46	8	3	1.980	2.060	1.5	6.5	¥ 1,800
No.3-48UNC	CPRTUN3F	46	8	3	2.250	2.350	1.5	6.5	¥ 2,100
No.3-56UNF	CPRTUN3E	46	8	3	2.290	2.370	1.5	6.5	¥ 2,100
No.4-40UNC	CPRTUN4H	46	8.5	4	2.540	2.640	1.5	7	¥ 2,000
No.4-48UNF	CPRTUN4F	46	8.5	4	2.590	2.680	1.5	7	¥ 2,000
No.5-40UNC	CPRTUN5H	46	8.5	4	2.870	2.970	1.5	7	¥ 2,100
No.5-44UNF	CPRTUN5G	46	8.5	4	2.900	2.990	1.5	7	¥ 2,100
No.6-32UNC	CPRTUN6J	52	10.5	5	3.110	3.220	2.25	8.3	¥ 2,100
No.6-40UNF	CPRTUN6H	52	10.5	5	3.190	3.290	2.25	8.3	¥ 2,100
No.8-32UNC	CPRTUN8J	52	10.5	5	3.780	3.890	2.25	8.3	¥ 2,300
No.8-36UNF	CPRTUN8I	52	10.5	5	3.810	3.910	2.25	8.3	¥ 2,300
No.10-24UNC	CPRTUNAM	59.5	12.5	5.5	4.300	4.440	2.5	10	¥ 2,320
No.10-32UNF	CPRTUNAJ	59.5	12.5	5.5	4.440	4.530	2.5	10	¥ 2,320
No.12-24UNC	CPRTUNCM	61.5	16.5	6	4.960	5.070	3.75	12.8	¥ 2,500
No.12-28UNF	CPRTUNCK	61.5	16.5	6	5.030	5.130	3.75	12.8	¥ 2,500
1/4-20UNC	CPRTU04N	61.5	16.5	6	5.730	5.860	3.75	12.8	¥ 2,600
1/4-28UNF	CPRTU04K	61.5	16.5	6	5.910	6.000	3.75	12.8	¥ 2,600
5/16-18UNC	CPRTU05O	90	19.4	8	7.230	7.380	4.7	14.7	¥ 2,800
5/16-24UNF	CPRTU05M	90	19.4	8	7.420	7.530	4.7	14.7	¥ 2,800
3/8-16UNC	CPRTU06P	100	23.4	10	8.720	8.890	6.7	16.7	¥ 2,850
3/8-24UNF	CPRTU06M	100	23.4	10	8.990	9.100	6.7	16.7	¥ 2,850
7/16-14UNC	CPRTU07O	110	27.4	12	10.200	10.400	7.7	19.7	¥ 2,900
7/16-20UNF	CPRTU07N	110	27.4	12	10.480	10.620	7.7	19.7	¥ 2,900
1/2-13UNC	CPRTU08R	110	27.4	12	11.700	11.920	7.7	19.7	¥ 3,100
1/2-20UNF	CPRTU08N	110	27.4	12	12.060	12.200	7.7	19.7	¥ 3,100

参考資料

①めねじの下穴径とひっかかり率

下穴径とひっかかり率の関係

(単位mm)

ねじ	下穴径 ⁽²⁾							めねじ内径 ⁽³⁾				
	ひっかかり率(%)							最小許容寸法	最大許容寸法			
	100	95	90	85	80	75	70		5 H (M 1.6以上) 1級	6 H (M 1.6以上) 2級	7 H 3級	
M2×0.4	1.57	1.59	1.61	1.63	1.65	1.68	1.70	1.567	1.657	1.679	—	
M2.5×0.45	2.01	2.04	2.06	2.09	2.11	2.13	2.16	2.013	2.113	2.138	—	
M3×0.5	2.4	2.49	2.51	2.54	2.57	2.59	2.62	2.459	2.571	2.599	2.639	
M4×0.7	3.24	3.28	3.32	3.36	3.39	3.43	3.47	3.242	3.382	3.422	3.466	
M5×0.8	4.13	4.18	4.22	4.26	4.31	4.35	4.39	4.134	4.294	4.334	4.384	
M6×1	4.92	4.97	5.03	5.08	5.13	5.19	5.24	4.917	5.107	5.153	5.217	
M8×1.25	6.65	6.71	6.78	6.85	6.92	6.99	7.05	6.647	6.859	6.912	6.982	
M10×1.5	8.38	8.46	8.54	8.62	8.70	8.78	8.86	8.376	8.612	8.676	8.751	
M12×1.75	10.1	10.2	10.3	10.4	10.5	10.6	10.7	10.106	10.371	10.441	10.531	

---線は5 H又は1級、 ---線は6 H又は2級、 ---線からの左側の太字体のものは7 H又は3級のめねじ内径の許容限界寸法内にあることを示す。(JIS B 1004:2009ねじ下穴径より抜粋)

②ひっかかり率とは

ひっかかり率(%) / Percentage of Thread Engagement

$$\frac{\text{外径の基準寸法} - \text{下穴径}}{2 \times (\text{標準のひっかかり高さ})} \times 100$$

$$\frac{\text{Basic Major Dia.} - \text{Hole Size Before Tapping}}{2 \times (\text{Basic Thread Overlap})} \times 100$$

基準のひっかかり高さ / Basic Thread Overlap :

メートルねじ、ユニファイねじ / Metric & Unified Thread	0.5413P
ワイトねじ / Whitworth Thread	0.5664P
管用ねじ (Rc, Rp, G, PT, PS, PF) / Pipe Thread	0.6403P

P=ピッチ、Pitch

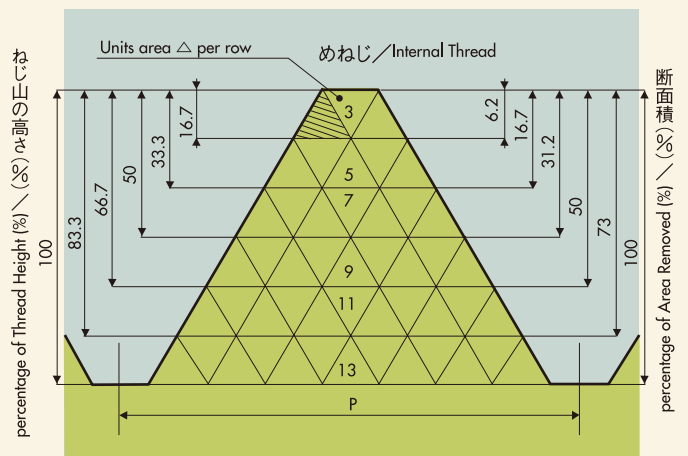

取り扱い上の注意点

- ◆機械での使用は事故の原因になるため、使用しないでください。
- ◆チェックピンには、過大な力を掛けないで下さい。
- ◆破損する危険があるので、カバー・保護めがねなどを使用してください。
- ◆ご使用後は錆防止の為、防錆処理を行って下さい。
- ◆製品チェックピンはきれいに清掃してから、ご使用下さい。

株式会社 彌満和製作所

本社 〒104-0031 東京都中央区京橋3-13-10 (中島ゴールドビル)

フリーダイヤル ヤマワハヨイヤ

●タッピング技術相談室 : ☎0120-800-418

●ホームページアドレス : <https://www.yamawa.com/jp>

YAMAWAグループ (株)やまわエンジニアリングサービス (株)やまわインターナショナル



未来のためのエコアクション
品質に影響を与えない部位の仕上げ加工を
簡素にして環境負荷低減に取り組んでいます
YAMAWA



SGCPSA